

THH **SERIES A**

ENGINEERING GUIDE



THHP



THHE

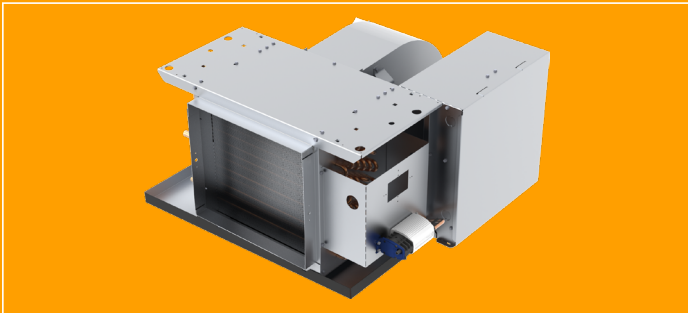

THHC



TABLE OF CONTENTS

Features and Benefits	3
Construction Features	4
Standard and Optional Features	6
Coils, Physical Data	7
Unit Weight Data	8
Heating Capacity / AHRI Standard Ratings.....	9
Electric Heat	10
Fan Performance Curves, PSC.....	11
Motor and Fan Data	13
Unit Arrangements	15
Dimensional Data	17
Field Connections	37
Valve Package Connections	50
Coil Connections	53
Guide Specifications	54



NOTES:

- Titus offers Selection software, the industry’s first web-based rating and selection program for complete unit, coil and sound selection. See your representative or visit our website at www.titus-hvac.com for more information.
- Some drawings are not shown in this catalog.
- All data herein is subject to change without notice.
- Drawings not for installation purposes.
- ETL Report Number 3036742-001.

FEATURES AND BENEFITS

HIGH PERFORMANCE

The Titus THH Series-A horizontal high performance fan coil units are designed to maximize flexibility of selection and installation.

The units are also designed to exceed the stringent quality standards of the institutional market, while remaining cost competitive in the light commercial segment of the market.

Titus horizontal fan coil units set the new standards for quality, flexibility, and competitive pricing.

DESIGN FLEXIBILITY

The extensive variety of standard options available on the THH Series-A units are where you find the versatility to fit any HVAC system designer's needs.

Options include: mixing box with linkage, rear or bottom ducted return, foil faced or elastomeric closed cell foam insulation, solid or telescoping bottom panels for unit recessing, single wall stainless steel drain pans, and electric heat with single power connection. All electric heat units are listed with ETL as an assembly and carry the cETL label.

All units comply with the latest edition of AHRI Standard 440 for testing and rating fan coil units, are certified, and display the AHRI symbol.

High efficiency motors, fan relays, disconnects and fusing mean easier coordination between mechanical and electrical trades.

Coil options allow for three, four or six row chilled water or DX coils. One to four row hot water or one and two row standard steam coils may be placed in the preheat or reheat position.

CONVENIENT INSTALLATION

All THH Series-A fan coil units are shipped completely assembled, reducing field installation time and labor. All units are thoroughly inspected and tested prior to shipment, eliminating potential problems at startup. Motor wiring is brought to a junction box on the outside of the unit casing, reducing electrical hook-up time.

Plenum units are field convertible for either rear or bottom return without the need for special adapters and tools.

All THH Series-A fan coil units have a bottom and side access electrical enclosure, allowing easy access to all electrical components, terminal blocks and wiring.

Available factory installed control packages can greatly reduce field labor and setup time. Consisting of control transformer and all needed relays, these packages integrate seamlessly with either factory provided thermostats or field installed thermostats and controllers.

Factory furnished valve packages assure proper fit, operation and performance. Valve packages are completely assembled and shipped loose with the units.

QUALITY PRODUCT

THH Series-A fan coil units are built from galvanized steel. Exposed Model THHE cabinetry is powder coated galvanized steel.

Standard insulation is 1/2 inch thick fiberglass, complying with UL 181 and NFPA 90A. Optional foil faced or elastomeric closed cell foam insulation may be specified.

All units, with or without electric heat, are cETL listed and labeled. All wiring is in compliance with NEC, assuring safety and quality for the owner.

THH Series-A fan coil units have a removable fan assembly. The entire fan assembly can be removed from the unit and serviced easily on a workbench.

CONSTRUCTION FEATURES

MODEL THHP

THH Series-A fan coils have many standard and optional features which are unique to the industry (see page 6 for a complete listing).

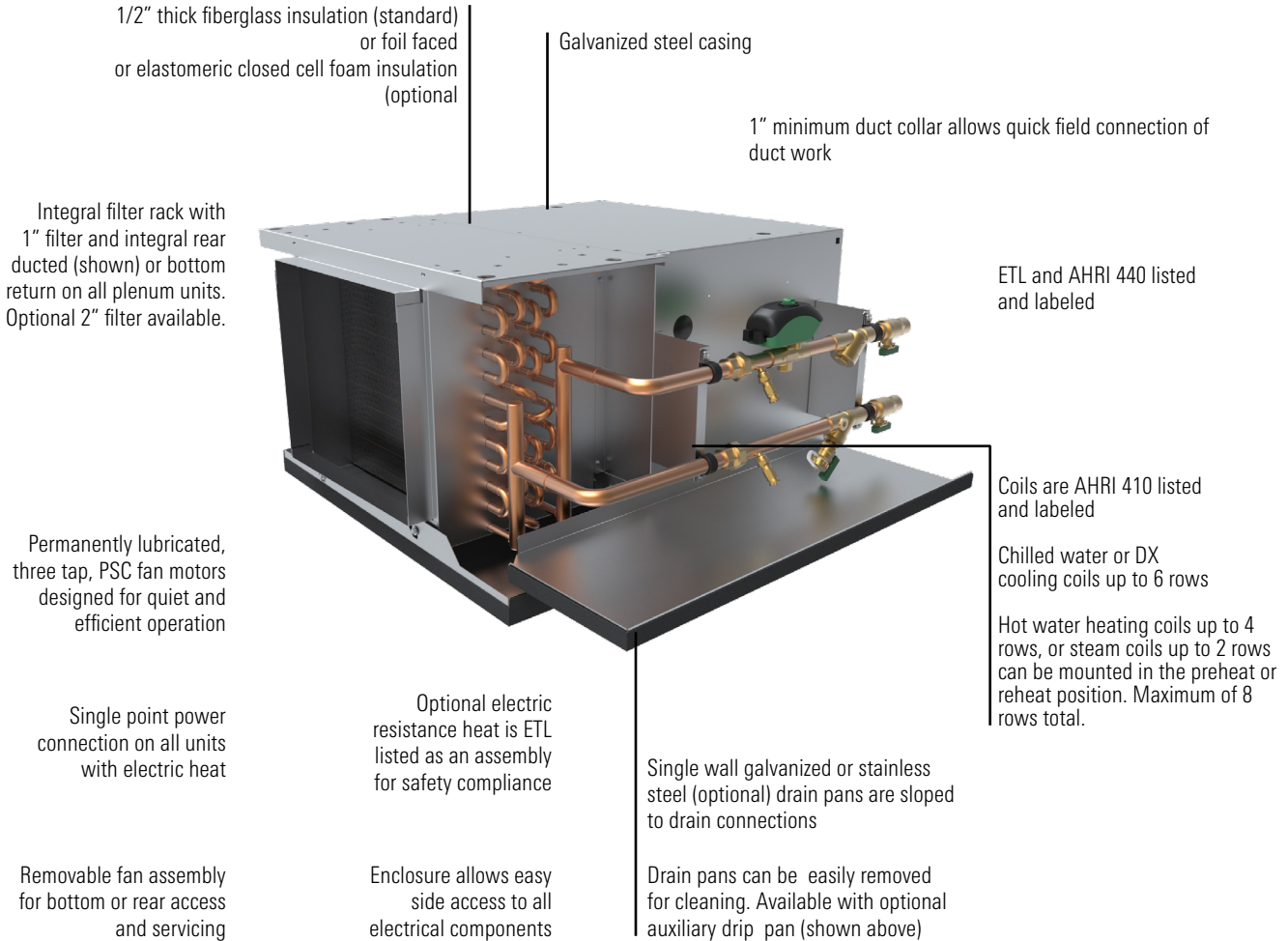

MODEL THHE
Horizontal Exposed Cabinet



MODEL THHC
Horizontal Free Return

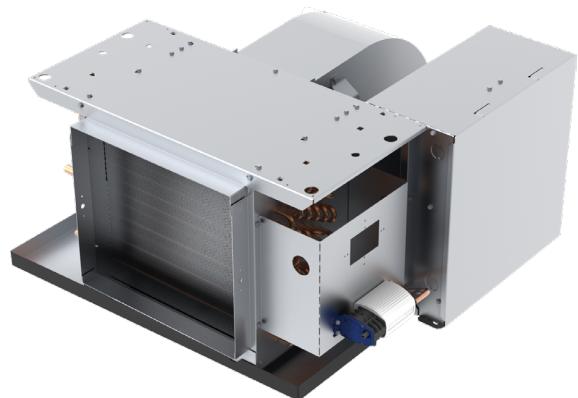

CONSTRUCTION FEATURES

MODELS THHC / THHP / THHE

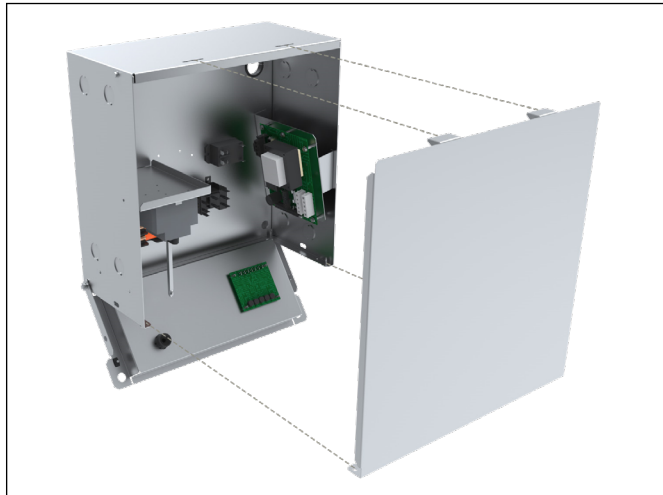

ELECTRICAL ENCLOSURE

The side access electrical enclosure provides access to all electric heat and control components. Terminal strips are furnished for simple power and control wiring connections. Multiple knockouts allow wiring entries from either side of the compartment.

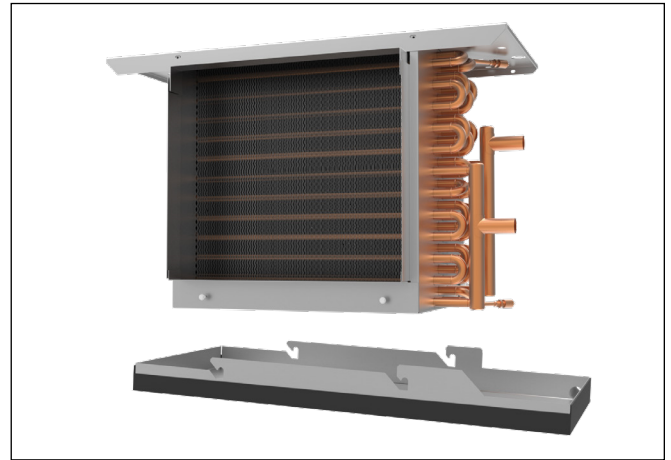

DRAIN PAN

Standard drain pans are externally insulated, single wall galvanized steel with an option for stainless steel. Drain pans are available with secondary drain connection. On concealed models, the THH Series-A drain pan is easily removable for cleaning.



MIXING BOX

The optional fully insulated mixing box section comes completely assembled to the THHP unit, featuring low leakage, heavy gauge steel dampers with integral linkage. Damper positioning is field configurable and bottom filter access is standard. An optional factory provided and installed damper actuator is also available.

COILS

All fan coils are available in 2 or 4 pipe configurations. The heating coil may be placed in the reheat or preheat position.

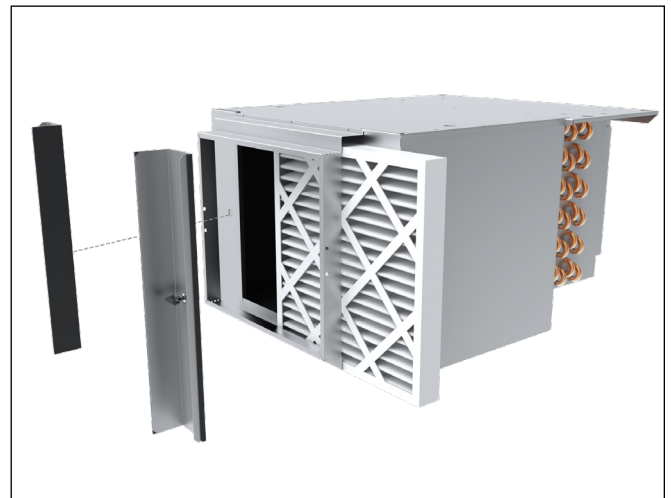

FILTERS

One inch throwaway filters are tight fitting to prevent air bypass. Filters are easily removable from the bottom without the need for tools. The filter rack is convertible from rear to bottom return without the need for additional parts. Optional 1" and 2" pleated filters are available for use with the THHP unit.

POWDER COATED PAINTED SURFACE

Exposed cabinet Model THHE features powder coat finish that resists scuffing, scratching, fading, and fingerprints.



FEATURES AND OPTIONS

STANDARD FEATURES

Construction

All Units

- AHRI 440 certified and labeled
- Galvanized steel construction
- 1/2" thick fiberglass insulation
- 1 1/2" duct discharge collar
- Holes are provided at four points for hanging units

Plenum units

- Integral filter rack with 1" throwaway filter
- Integral rear ducted return - field reversible to bottom return

Exposed units

- Single deflection rear return grille
- Double deflection discharge grille
- Durable powder coat paint
- 18 gauge cabinet construction

Coils

- AHRI 410 certified and labeled
- Cooling - 3, 4 or 6 row chilled water or DX, heat pump compatible
- Heating - 1, 2, 3 or 4 row hot water or 1 or 2 row steam - reheat or preheat position
- 8 total rows of cooling and heating coils maximum
- 3/8" O.D. seamless copper tubes
- 0.012" tube wall thickness
- High efficiency aluminum fin surface for optimizing heat transfer, pressure drop and carryover
- Left or right hand connections
- Removable for service
- Manual air vent

Drain Pans

- Single wall, galvanized steel, externally insulated – fire retardant and antimicrobial closed cell foam
- Sloped to drain connection
- Tool-free removable
- 7/8" O.D. primary drain connection

Fan Assemblies

- Forward curved, DWDI centrifugal type
- 115 volt, single phase, three tap PSC motors
- Quick disconnect motor connections
- Removable fan(s)/motor(s) for service

Electrical

- cETL listed for safety compliance
- Electrical junction box for field wiring terminations
- Terminal block for field connections

Electric Heat

- cETL listed as an assembly for safety compliance
- Integral electric heat assembly with removable electric heat rack for easy service
- Automatic reset primary and back-up secondary thermal limits
- Single point power connection
- Bottom-hinged electrical enclosure

OPTIONAL FEATURES

Construction

All units

- Foil faced fiberglass insulation
- Elastomeric closed cell foam insulation

Plenum units

- Bottom return
- Mixing box with top/rear or rear/bottom dampers - field reversible
- Damper actuator
- Spare 1" throwaway filters
- 1" and 2" pleated filters

Exposed units

- Single deflection bottom return grille
- Ducted supply
- Ducted rear return

Coils

- 1/2" O.D. seamless copper tubes
- 0.016" tube wall thickness
- 0.025" tube wall thickness
- Automatic air vents
- Stainless steel coil casings

Drain Pans

- Stainless steel with external insulation
- 5/8" O.D. secondary drain connection
- Auxiliary drip pan

Fan Assemblies

- 208-230 & 277 volt, single phase, three tap PSC motors
- ECM™ motors

Electrical

- Side access electrical enclosure
- Silent solid state fan relays
- SCR fan speed controller (only for high speed)
- Toggle disconnect switch
- Condensate overflow switch (drain pan)
- Main fusing
- Unit and remote mounted three speed fan switches
- Fan relay packages
- Control power transformers

Electric Heat

- Door interlocking disconnect switches
- Main fusing
- Silent relay / contactor

Piping Packages

- Factory assembled – shipped loose or pre-installed
- 1/2", 3/4", and 1", 2 way and 3 way normally closed, two position electric motorized valves
- Isolation ball valves with memory stop
- Fixed and adjustable flow control devices
- Unions and P/T ports
- Modulating control valves

Thermostats

- Remote mounted analog, digital display or programmable
- 2 and 4 pipe control sequences
- Automatic and manual changeover
- Integral three speed fan switches

COILS, PHYSICAL DATA

COILS

Titus offers hot water, chilled water, direct expansion (DX), and standard steam coils for specific application with all THH Series-A Fan Coil Units. Strict on-site inspection before, during, and after installation guarantees the highest quality and performance available.

STANDARD FEATURES

- Cooling - 3, 4 or 6 row chilled water or DX
- Heating - 1, 2, 3 or 4 row hot water, or 1 or 2 row steam
- 8 total rows of cooling and heating coils maximum
- 3/8" O.D. seamless copper tubes
- 0.012" tube wall thickness
- High efficiency aluminum fin surface for optimizing heattransfer, pressure drop and carryover
- Left or right hand connections
- Manual air vents

OPTIONAL FEATURES

- 1/2" O.D. seamless copper tubes
- 0.016" tube wall thickness
- 0.025" tube wall thickness
- Automatic air vents
- Stainless steel coil casings
- DX coils are heat pump compatible

Titus offers the industry's first web-based fan coil rating and selection program for complete unit, coil and sound selection. See your representative for more information.

NOMINAL COIL CONNECTION SIZES

UNIT SIZE	COIL TYPE						
	WATER					STEAM	
	1 ROW	2 ROW	3 ROW	4 ROW	6 ROW	1 ROW	2 ROW
06	5/8 [16]	5/8 [16]	7/8 [22]	7/8 [22]	7/8 [22]	5/8 [16]	7/8 [22]
08	5/8 [16]	5/8 [16]	7/8 [22]	7/8 [22]	7/8 [22]	5/8 [16]	7/8 [22]
10	5/8 [16]	5/8 [16]	7/8 [22]	7/8 [22]	7/8 [22]	5/8 [16]	7/8 [22]
12	5/8 [16]	5/8 [16]	7/8 [22]	7/8 [22]	7/8 [22]	7/8 [22]	7/8 [22]
14	7/8 [22]	7/8 [22]	1 1/8 [29]	1 1/8 [29]	1 1/8 [29]	7/8 [22]	1 1/8 [29]
16	7/8 [22]	7/8 [22]	1 1/8 [29]	1 1/8 [29]	1 1/8 [29]	7/8 [22]	1 1/8 [29]
18	7/8 [22]	7/8 [22]	1 1/8 [29]	1 1/8 [29]	1 1/8 [29]	7/8 [22]	1 1/8 [29]
20	7/8 [22]	7/8 [22]	1 1/8 [29]	1 1/8 [29]	1 1/8 [29]	7/8 [22]	1 1/8 [29]

NOTES:

1. All dimensional data is outside diameter (O.D.), measured in inches [millimeters].
2. See submittal drawings for connection locations.
3. Connection sizes are for standard circuit coils. Consult factory for special applications.
4. Direct Expansion (DX) suction header connection sizes are either 5/8" [16mm] or 7/8" [22mm]. Refer to coil selection.
5. DX coils include a fixed orifice distributor for multi-circuited coils. A DX coil with a single circuit requires no distributor. Thermal expansion valves (TXV's) are field supplied by others.

FACE AREA, FREE AREA AND FILTER SIZES

UNIT SIZE	COIL FACE AREA	NOMINAL FILTER SIZES	1" THROWAWAY FACE AREA	1" PLEATED GROSS MEDIA AREA	2" PLEATED GROSS MEDIA AREA
06	1.46 [0.14]	(1) 16 x 16 [406 x 406]	1.62 [0.15]	4.0 [0.37]	5.4 [0.50]
08	1.94 [0.18]	(1) 16 x 20 [406 x 508]	2.04 [0.19]	4.8 [0.45]	6.8 [0.63]
10	2.33 [0.22]	(1) 16 x 25 [406 x 381]	2.57 [0.24]	6.0 [0.56]	8.5 [0.79]
12	2.82 [0.26]	(2) 16 x 16 [406 x 406]	3.23 [0.30]	8.0 [0.74]	10.4 [0.97]
14	3.31 [0.31]	(1) 16 x 16 & (1) 16 x 20 (1) [406 x 406] & (1) [406 x 508]	3.65 [0.34]	8.8 [0.82]	12.2 [1.13]
16	3.79 [0.35]	(2) 16 x 20 [406 x 508]	4.08 [0.38]	9.6 [0.89]	13.4 [1.24]
18	4.28 [0.40]	(1) 16 x 20 & (1) 16 x 25 (1) [406 x 508] & (1) [406 x 635]	4.61 [0.43]	10.8 [1.00]	14.3 [1.33]
20	4.67 [0.43]	(2) 16 x 25 [406 x 635]	5.14 [0.48]	12.0 [1.11]	17.0 [1.58]

NOTES:

1. Face and free areas are in square feet [square meters].
2. Filter sizes are in inches [millimeters].

PHYSICAL DATA

UNIT WEIGHT DATA - 1/2" COILS

COMPONENT		UNIT SIZE															
		6		8		10		12		14		16		18		20	
THHC Series-A BASE UNIT		68	[31]	73	[33]	77	[35]	114	[52]	119	[54]	124	[56]	128	[58]	132	[60]
THHP Series-A BASE UNIT		87	[39]	95	[43]	101	[46]	141	[64]	150	[68]	157	[71]	164	[74]	170	[77]
THHP Series-A WITH MIXING BOX		119	[54]	132	[60]	144	[65]	189	[86]	204	[93]	217	[98]	229	[104]	246	[112]
THHE Series-A BASE UNIT		137	[62]	146	[66]	158	[72]	202	[92]	219	[99]	228	[103]	240	[109]	250	[113]
THHE Series-A EXTENDED UNIT		162	[73]	171	[78]	183	[83]	227	[103]	244	[111]	253	[115]	265	[120]	275	[125]
TOTAL COIL ROWS	1 ROW - Dry	5	[2]	6	[3]	7	[3]	8	[4]	10	[5]	10	[5]	11	[5]	12	[5]
	1 ROW - Wet	7	[3.2]	9	[4.1]	10	[4.5]	11	[5]	14	[6.4]	14	[6.4]	16	[7.3]	17	[7.7]
	2 ROW - Dry	11	[5]	13	[5.9]	14	[6.4]	16	[7.3]	20	[9.1]	20	[9.1]	22	[10]	24	[10.9]
	2 ROW - Wet	14	[6.4]	18	[8.2]	20	[9.1]	23	[10.4]	27	[12.2]	28	[12.7]	32	[14.5]	35	[15.9]
	3 ROW - Dry	16	[7.3]	19	[8.6]	21	[9.5]	24	[10.9]	30	[13.6]	30	[13.6]	33	[15]	36	[16.3]
	3 ROW - Wet	21	[9.5]	27	[12.2]	30	[13.6]	34	[15.4]	41	[18.6]	42	[19.1]	48	[21.8]	52	[23.6]
	4 ROW - Dry	21	[9.5]	25	[11.3]	29	[13.2]	33	[15]	40	[18.1]	40	[18.1]	44	[20]	48	[21.8]
	4 ROW - Wet	27	[12.2]	35	[15.9]	41	[18.6]	46	[20.9]	54	[24.5]	56	[25.4]	64	[29]	69	[31.3]
	5 ROW - Dry	26	[11.8]	30	[13.6]	34	[15.4]	38	[17.2]	42	[19.1]	46	[20.9]	50	[22.7]	54	[24.5]
	5 ROW - Wet	33	[15]	39	[17.7]	45	[20.4]	51	[23.1]	57	[25.9]	63	[28.6]	70	[31.8]	77	[34.9]
	6 ROW - Dry	32	[14.5]	38	[17.2]	43	[19.5]	49	[22.2]	59	[26.8]	61	[27.7]	67	[30.4]	71	[32.2]
	6 ROW - Wet	42	[19.1]	53	[24]	61	[27.7]	69	[31.3]	80	[36.3]	85	[38.6]	97	[44]	103	[46.7]
	7 ROW - Dry	38	[17.2]	42	[19.1]	48	[21.8]	54	[24.5]	60	[27.2]	66	[29.9]	72	[32.7]	78	[35.4]
	7 ROW - Wet	49	[22.2]	56	[25.4]	63	[28.6]	70	[31.8]	77	[34.9]	84	[38.1]	91	[41.3]	98	[44.5]
	8 ROW - Dry	43	[19.5]	49	[22.2]	55	[24.9]	61	[27.7]	67	[30.4]	73	[33.1]	79	[35.8]	85	[38.6]
	8 ROW - Wet	55	[24.9]	63	[28.6]	71	[32.2]	79	[35.8]	87	[39.5]	95	[43.1]	103	[46.7]	111	[50.3]

NOTE: Unit weight data is in pounds [kilograms].

UNIT WEIGHT DATA - 3/8" COILS

COMPONENT		UNIT SIZE															
		6		8		10		12		14		16		18		20	
THHC Series-A BASE UNIT		68	[31]	73	[33]	77	[35]	114	[52]	119	[54]	124	[56]	128	[58]	132	[60]
THHP Series-A BASE UNIT		87	[39]	95	[43]	101	[46]	141	[64]	150	[68]	157	[71]	164	[74]	170	[77]
THHP Series-A WITH MIXING BOX		119	[54]	132	[60]	144	[65]	189	[86]	204	[93]	217	[98]	229	[104]	246	[112]
THHE Series-A BASE UNIT		137	[62]	146	[66]	158	[72]	202	[92]	219	[99]	228	[103]	240	[109]	250	[113]
THHE Series-A EXTENDED UNIT		162	[73]	171	[78]	183	[83]	227	[103]	244	[111]	253	[115]	265	[120]	275	[125]
TOTAL COIL ROWS	1 ROW - Dry	4	[1.7]	5	[2.1]	6	[2.6]	6	[2.9]	8	[3.6]	9	[3.9]	9	[4.3]	10	[4.5]
	1 ROW - Wet	5	[2.4]	7	[3.1]	8	[3.6]	9	[4]	11	[5]	12	[5.5]	14	[6.2]	14	[6.4]
	2 ROW - Dry	8	[3.8]	10	[4.5]	11	[5.1]	13	[5.8]	16	[7.1]	17	[7.8]	19	[8.5]	20	[9.1]
	2 ROW - Wet	11	[4.8]	14	[6.2]	16	[7.3]	18	[8.3]	21	[9.6]	24	[10.9]	27	[12.4]	29	[13.2]
	3 ROW - Dry	12	[5.5]	14	[6.5]	17	[7.7]	19	[8.7]	24	[10.7]	26	[11.7]	28	[12.8]	30	[13.6]
	3 ROW - Wet	16	[7.2]	20	[9.3]	24	[10.9]	27	[12.3]	32	[14.6]	36	[16.4]	41	[18.6]	43	[19.7]
	4 ROW - Dry	17	[7.9]	20	[9.2]	24	[10.8]	27	[12.2]	33	[14.8]	32	[14.7]	35	[16.1]	38	[17.4]
	4 ROW - Wet	20	[9.2]	27	[12]	33	[14.9]	37	[16.7]	42	[19.2]	48	[21.9]	55	[24.8]	58	[26.1]
	5 ROW - Dry	20	[8.9]	23	[10.3]	27	[12.4]	30	[13.8]	33	[14.9]	40	[18]	43	[19.4]	45	[20.4]
	5 ROW - Wet	25	[11.3]	30	[13.4]	36	[16.4]	41	[18.5]	45	[20.3]	54	[24.6]	60	[27.1]	64	[29.1]
	6 ROW - Dry	24	[11]	29	[13.1]	35	[15.7]	39	[17.8]	46	[21]	53	[23.8]	57	[25.9]	59	[26.9]
	6 ROW - Wet	32	[14.4]	40	[18.2]	49	[22.2]	55	[25]	63	[28.4]	73	[33.2]	83	[37.5]	86	[39]
	7 ROW - Dry	29	[13]	32	[14.4]	39	[17.5]	43	[19.6]	47	[21.3]	57	[25.8]	61	[27.9]	65	[29.5]
	7 ROW - Wet	37	[16.8]	42	[19.3]	51	[23]	56	[25.4]	60	[27.4]	72	[32.8]	78	[35.2]	82	[37.1]
	8 ROW - Dry	32	[14.7]	37	[16.8]	44	[20]	49	[22.1]	53	[23.8]	63	[28.5]	67	[30.6]	71	[32.1]
	8 ROW - Wet	42	[18.8]	48	[21.7]	57	[25.9]	63	[28.7]	68	[30.9]	82	[37.1]	88	[39.9]	93	[42]

NOTE: Unit weight data is in pounds [kilograms].

HEATING CAPACITY / AHRI STANDARD RATINGS

HEATING CAPACITY

UNIT TYPE	UNIT SIZE	NOM. CFM	1 ROW			2 ROW			3 ROW			4 ROW		
			QS (MBH)	GPM	WPD	QS (MBH)	GPM	WPD	QS (MBH)	GPM	WPD	QS (MBH)	GPM	WPD
THHC THHP THHE	06	600	17.5	0.9	1.6	30.2	1.5	1.4	41.7	2.1	1.0	48.3	2.5	0.9
	08	800	24.3	1.2	3.2	41.8	2.1	2.6	57.6	2.9	2.0	66.5	3.4	1.6
	10	1000	27.8	1.4	0.8	52.4	2.7	4.1	70.5	3.6	1.5	80.6	4.1	1.0
	12	1200	34.5	1.8	0.9	61.8	3.2	1.8	86.4	4.4	2.3	98.8	5.1	1.6
	14	1400	41.3	2.1	1.7	73.4	3.8	2.6	98.6	5.0	1.4	117.1	6.0	1.8
	16	1600	48.1	2.5	2.4	85.1	4.4	3.6	114.5	5.9	1.9	126.5	6.5	0.6
	18	1800	54.9	2.8	3.2	96.8	5.0	4.9	130.4	6.7	2.5	144.7	7.4	0.7
	20	2000	61.0	3.1	4.1	107.5	5.5	6.1	145.3	7.4	2.4	161.7	8.3	0.9

NOTES:

- Based on 70°F DB EAT, 180°F EWT, 40°F temperature drop, high fan speed.
- THHE performance data varies from THHC and THHP units. Please use Selection software at www.titushvac.com for THHE data.

AHRI STANDARD RATINGS

Model	Size	AHRI 400	Coil		Airflow CFM (Dry flow)	Cooling Capacity		Water		Power Input (Watts)
			Rows	FPI		QT (BTUH)	QS (BTUH)	Flow Rate (GPM)	WPD (ft-wg)	
THHC	6	YES	4	12	668	21500	15800	4.9	8.4	229
THHC	8	YES	4	12	922	29900	21800	6.7	9.3	377
THHC	10	YES	4	12	939	30000	22200	6.7	4.2	419
THHC	12	YES	4	12	1459	40700	31500	9.4	4.3	517
THHC	14	YES	4	12	1748	53000	39500	12	7.9	683
THHC	16	YES	4	12	1985	53000	42100	12	2.5	864
THHC	18	YES	4	12	2005	59500	45300	13.5	3.5	835
THHC	20	YES	4	12	1986	62800	46600	14.1	4	706
THHP	6	YES	4	12	642	21000	15400	4.8	8.2	235
THHP	8	YES	4	12	900	29600	21500	6.7	9.3	386
THHP	10	YES	4	12	918	29700	21900	6.7	4.2	426
THHP	12	YES	4	12	1398	39700	30600	9.2	4.1	529
THHP	14	YES	4	12	1698	51800	38600	11.7	7.5	701
THHP	16	YES	4	12	1936	51800	41100	11.7	2.4	882
THHP	18	YES	4	12	1938	58100	44100	13.2	3.3	815
THHP	20	YES	4	12	1947	62200	46000	14.1	4	721
THHE	6	YES	4	12	663	21500	15700	4.9	8.4	230
THHE	8	YES	4	12	918	26900	20500	6	4.6	379
THHE	10	YES	4	12	957	30800	22800	7	4.6	413
THHE	12	YES	4	12	1431	40400	31100	9.4	4.3	522
THHE	14	YES	4	12	1710	51900	38700	11.7	7.5	697
THHE	16	YES	4	12	1970	52800	41900	12	2.5	872
THHE	18	YES	4	12	2007	59500	45300	13.5	3.5	835
THHE	20	YES	4	12	2002	63500	47100	14.3	4.2	699

NOTES:

- Based on 80°F DB and 67°F WB EAT, 45°F EWT, 10°F temperature rise, high fan speed. Motor type is PSC and motor voltage is 115/1/60. Airflow under dry coil conditions. All models tested at 0.05" external static pressure.
- Airflow rate CFM on sizes 14 through 20 exceed maximum ratings in AHRI 440 and are outside of the scope of certification.

ELECTRIC HEAT

STANDARD FEATURES

- ETL listed as an assembly for safety compliance
- Single point power connection
- Mounted in preheat position
- Automatic reset primary and back-up secondary thermal limits
- Internal wiring rated at 105°C
- Integral electric heat assembly with removable element for easy service



USEFUL FORMULAS

$$\text{kW}^* = \frac{\text{CFM} \times \Delta T \times 1.085^{**}}{3413}$$

$$1\emptyset \text{ AMPs} = \frac{\text{kW} \times 1000}{\text{Volts}}$$

- * 1kW = 3413 BTU/H
- ** Capacity at sea level

Altitude Considerations:

Reduce by 0.034 for each 1000 ft. of altitude above sea level.

Example: 5000 ft./1000 ft. = 5

5 x 0.034 = 0.17

1.085 - 0.17 = 0.915

OPTIONAL FEATURES

- Solid state silent relay
- Door interlocking disconnect switch
- Main fusing (for equal to or less than 48 AMPs)

ELECTRICAL CALCULATIONS INFORMATION

1. Refer to MCA/MOP values from performance printouts from software.
2. Non-Fused Door Interlock Disconnect Switch shall be sized according to MCA.
3. Fused Door Interlock Disconnect Switch and Main Fusing shall be sized according to MOP.

ELECTRIC HEAT SELECTION CHART (AMPS)

UNIT SIZE	MBH	6.8	8.5	10.2	11.9	13.7	17.1	20.5	23.9	27.3	30.7	34.1	41.0	47.8
	KW	2.0	2.5	3.0	3.5	4.0	5.0	6.0	7.0	8.0	9.0	10.0	12.0	14.0
	VOLTS	AMPS												
06	115	17.4	21.7	26.1	30.4	34.8								
	208	9.6	12.0	14.4	16.8	19.2								
	230	8.7	10.9	13.0	15.2	17.4								
	277	7.2	9.0	10.8	12.6	14.4								
08	115	17.4	21.7	26.1	30.4	34.8	43.5							
	208	9.6	12.0	14.4	16.8	19.2	24.0	28.8						
	230	8.7	10.9	13.0	15.2	17.4	21.7	26.1						
	277	7.2	9.0	10.8	12.6	14.4	18.1	21.7						
10	115	17.4	21.7	26.1	30.4	34.8	43.5							
	208	9.6	12.0	14.4	16.8	19.2	24.0	28.8	33.7					
	230	8.7	10.9	13.0	15.2	17.4	21.7	26.1	30.4					
	277	7.2	9.0	10.8	12.6	14.4	18.1	21.7	25.3					
12	115					34.8	43.5							
	208					19.2	24.0	28.8	33.7	38.5	43.3			
	230					17.4	21.7	26.1	30.4	34.8	39.1			
	277					14.4	18.1	21.7	25.3	28.9	32.5			
14	115					34.8	43.5							
	208					19.2	24.0	28.8	33.7	38.5	43.3	48.1		
	230					17.4	21.7	26.1	30.4	34.8	39.1	43.5		
	277					14.4	18.1	21.7	25.3	28.9	32.5	36.1		
16	115					34.8	43.5							
	208					19.2	24.0	28.8	33.7	38.5	43.3	48.1	57.7	
	230					17.4	21.7	26.1	30.4	34.8	39.1	43.5	52.2	
	277					14.4	18.1	21.7	25.3	28.9	32.5	36.1	43.3	
18	115					34.8	43.5							
	208					19.2	24.0	28.8	33.7	38.5	43.3	48.1	57.7	
	230					17.4	21.7	26.1	30.4	34.8	39.1	43.5	52.2	
	277					14.4	18.1	21.7	25.3	28.9	32.5	36.1	43.3	
20	115					34.8	43.5							
	208					19.2	24.0	28.8	33.7	38.5	43.3	48.1	57.7	67.3
	230					17.4	21.7	26.1	30.4	34.8	39.1	43.5	52.2	60.9
	277					14.4	18.1	21.7	25.3	28.9	32.5	36.1	43.3	50.5

NOTES:

1. Shaded areas indicate kW and voltage options not available.
2. Available voltages are single phase, 60 hertz.
3. Heaters over 48 AMPs are subdivided and fused per NEC.

FAN PERFORMANCE CURVES, PSC

GENERAL FAN NOTES, PSC MOTORS

1. Fan curves depict actual performance of each motor tap without any additional fan balance adjustment. Actual capacities which fall below each curve can be obtained by adding an adjustment device. Units should not be run prior to installation of downstream ductwork; otherwise, damage to the motor may result.
2. Titus Fan Coil Units are equipped with permanent split-capacitor (PSC) motors with three separate taps (High, Medium and Low) which provide variable horsepower outputs. Most often, size selections are conservative and actual CFM requirements and/or external static pressure requirements are lower than those specified. In this case, the unit fan motor can be run at low or medium tap, substantially reducing the operating cost of the unit.
3. All fan curves are for 115/1/60 motors and include pressure losses for cabinet, electric heater, and 3 or 4 row coil. Plenum units include a clean 1" throwaway filter. For other coil configurations, adjust performance curves based on pressure losses for the coils as selected with the Titus Software Program.
4. See page 18 for fan motor electrical data.
5. For additional high static pressure applications and rating points, contact factory.

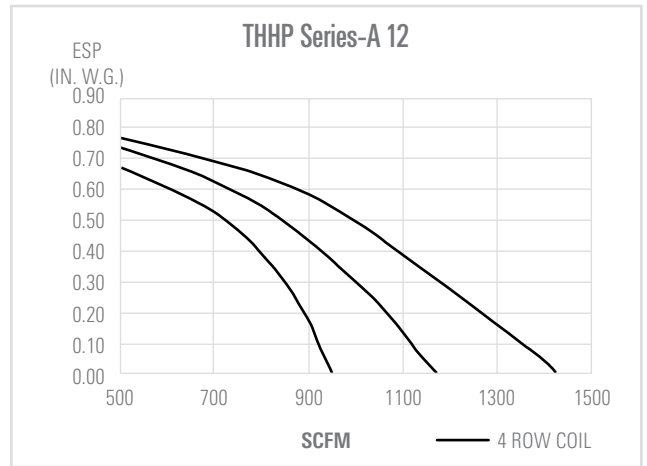
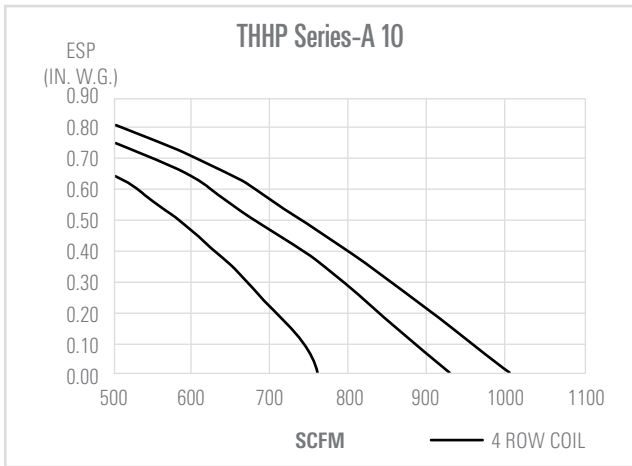
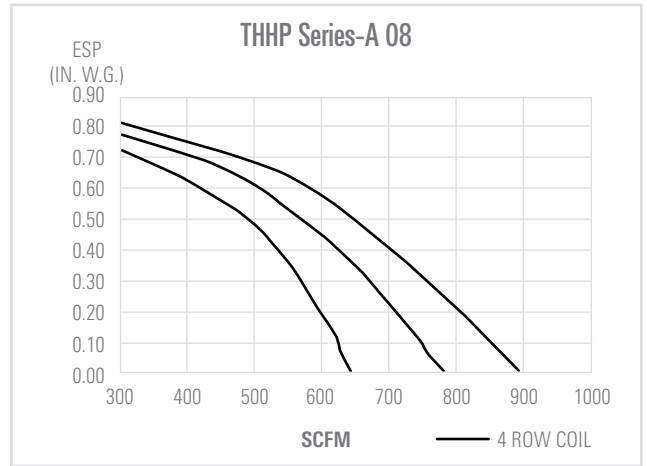
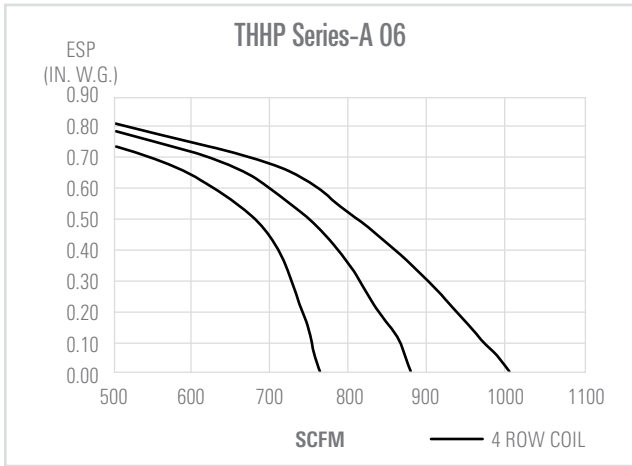

FAN PERFORMANCE CURVES, PSC

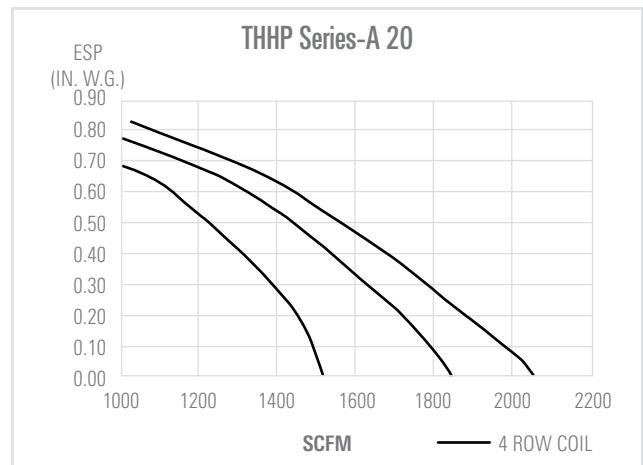
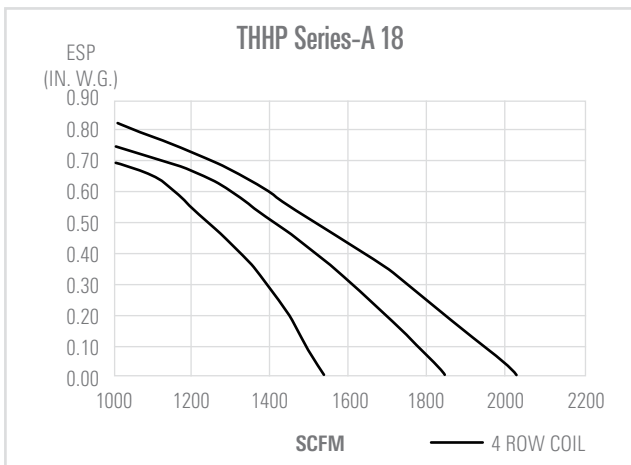
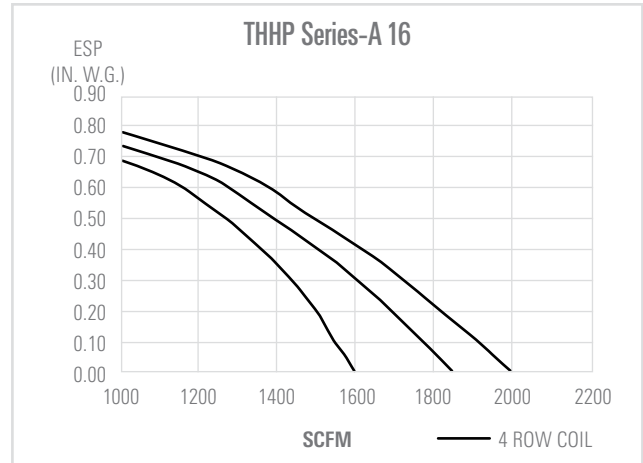
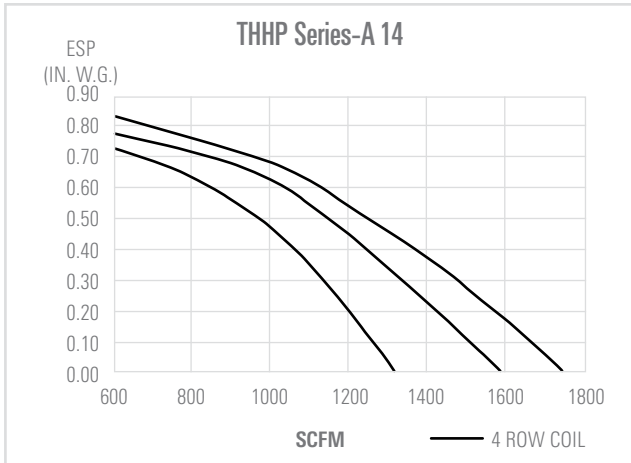

MOTOR AND FAN DATA

UNIT SIZE	FAN SPEED	MOTOR HP (Quantity)			# OF FANS	Amps @ 120V/1/60				
		PSC	ECM	ECM3		PSC	ECM		ECM 3-SPD	
						FLA	FLA	3-Phase Neutral Current	FLA	3-Phase Neutral Current
06	High	(1) 1/6	(1) 1/3	(1) 1/3	1	2.6	4.9	8.5	4.8	8.3
	Medium	(1) 1/8				2.1				
	Low	(1) 1/10				1.8				
08	High	(1) 1/4	(1) 1/3	(1) 1/3	1	4.4	5	8.7	4.8	8.3
	Medium	(1) 1/6				3.6				
	Low	(1) 1/8				3.0				
10	High	(1) 1/4	(1) 1/3	(1) 1/3	1	4.9	5	8.7	4.8	8.3
	Medium	(1) 1/5				4.1				
	Low	(1) 1/6				3.2				
12	High	(2) 1/6	(1) 1/2	(2) 1/3	2	5.2	7.7	13.3	9.6	16.6
	Medium	(2) 1/8				4.2				
	Low	(2) 1/10				3.6				
14	High	(2) 1/4	(2) 1/3	(2) 1/3	2	8.8	10	17.3	9.6	16.6
	Medium	(2) 1/6				7.2				
	Low	(2) 1/8				6.0				
16	High	(2) 1/4	(2) 1/3	(2) 1/3	2	9.8	10	17.3	9.6	16.6
	Medium	(2) 1/5				8.2				
	Low	(2) 1/6				6.4				
18	High	(2) 1/4	(2) 1/3	(2) 1/3	2	9.8	10	17.3	9.6	16.6
	Medium	(2) 1/5				8.2				
	Low	(2) 1/6				6.4				
20	High	(2) 1/4	(2) 1/2	(2) 1/3	2	9.8	13	22.5	9.6	16.6
	Medium	(2) 1/5				8.2				
	Low	(2) 1/6				6.4				

UNIT SIZE	FAN SPEED	MOTOR HP (Quantity)			# OF FANS	Amps @ 208V-230V/1/60				
		PSC	ECM	ECM3		PSC	ECM		ECM 3-SPD	
						FLA	FLA	3-Phase Neutral Current	FLA	3-Phase Neutral Current
06	High	(1) 1/6	(1) 1/3	(1) 1/3	1	1.0	3	5.2	2.8	4.8
	Medium	(1) 1/8				0.9				
	Low	(1) 1/10				0.6				
08	High	(1) 1/4	(1) 1/3	(1) 1/3	1	1.6	3	5.2	2.8	4.8
	Medium	(1) 1/6				1.0				
	Low	(1) 1/8				0.8				
10	High	(1) 1/4	(1) 1/3	(1) 1/3	1	2.0	3	5.2	2.8	4.8
	Medium	(1) 1/5				1.4				
	Low	(1) 1/6				1.2				
12	High	(2) 1/6	(1) 1/2	(2) 1/3	2	2.0	4.8	8.3	5.6	9.7
	Medium	(2) 1/8				1.8				
	Low	(2) 1/10				1.2				
14	High	(2) 1/4	(2) 1/3	(2) 1/3	2	3.2	6	10.4	5.6	9.7
	Medium	(2) 1/6				2.0				
	Low	(2) 1/8				1.6				
16	High	(2) 1/4	(2) 1/3	(2) 1/3	2	4.0	6	10.4	5.6	9.7
	Medium	(2) 1/5				2.8				
	Low	(2) 1/6				2.4				
18	High	(2) 1/4	(2) 1/3	(2) 1/3	2	4.0	6	10.4	5.6	9.7
	Medium	(2) 1/5				2.8				
	Low	(2) 1/6				2.4				
20	High	(2) 1/4	(2) 1/2	(2) 1/3	2	4.0	8	13.9	5.6	9.7
	Medium	(2) 1/5				2.8				
	Low	(2) 1/6				2.4				

NOTES:

1. Motor electrical data is nameplate data. Actual data will vary with application.
2. Motors nameplated for 208-230/1/60. Data is at 230 volts.
3. ECM motors operated on 208/1/60 power result in reduced airflow.

MOTOR AND FAN DATA

UNIT SIZE	FAN SPEED	MOTOR HP (Quantity)			# OF FANS	Amps @ 277V/1/60				
		PSC	ECM	ECM3		PSC	ECM		ECM 3-SPD	
						FLA	FLA	3-Phase Neutral Current	FLA	3-Phase Neutral Current
06	High	(1) 1/6	(1) 1/3	(1) 1/3	1	0.9	2.4	4.2	2.6	4.5
	Medium	(1) 1/8				0.8				
	Low	(1) 1/10				0.7				
08	High	(1) 1/4	(1) 1/3	(1) 1/3	1	1.3	2.6	4.5	2.6	4.5
	Medium	(1) 1/6				0.8				
	Low	(1) 1/8				0.6				
10	High	(1) 1/4	(1) 1/3	(1) 1/3	1	1.9	2.6	4.5	2.6	4.5
	Medium	(1) 1/5				1.6				
	Low	(1) 1/6				1.3				
12	High	(2) 1/6	(1) 1/2	(2) 1/3	2	1.8	3.9	6.8	5.2	9.0
	Medium	(2) 1/8				1.6				
	Low	(2) 1/10				1.4				
14	High	(2) 1/4	(2) 1/3	(2) 1/3	2	2.6	5.2	9.0	5.2	9.0
	Medium	(2) 1/6				1.6				
	Low	(2) 1/8				1.2				
16	High	(2) 1/4	(2) 1/3	(2) 1/3	2	3.8	5.2	9.0	5.2	9.0
	Medium	(2) 1/5				3.2				
	Low	(2) 1/6				2.6				
18	High	(2) 1/4	(2) 1/3	(2) 1/3	2	3.8	5.2	9.0	5.2	9.0
	Medium	(2) 1/5				3.2				
	Low	(2) 1/6				2.6				
20	High	(2) 1/4	(2) 1/2	(2) 1/3	2	3.8	6.4	11.1	5.2	9.0
	Medium	(2) 1/5				3.2				
	Low	(2) 1/6				2.6				

NOTES:

1. Motor electrical data is nameplate data. Actual data will vary with application.
2. Motors nameplated for 208-230/1/60. Data is at 230 volts.
3. ECM motors operated on 208/1/60 power result in reduced airflow.

UNIT ARRANGEMENTS

THHP BOTTOM RETURN

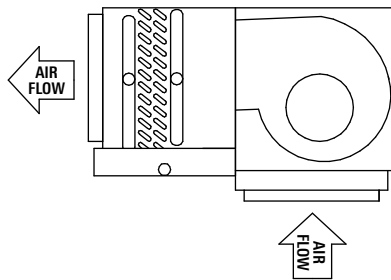

THHP REAR RETURN WITH SOLID ACCESS PANEL

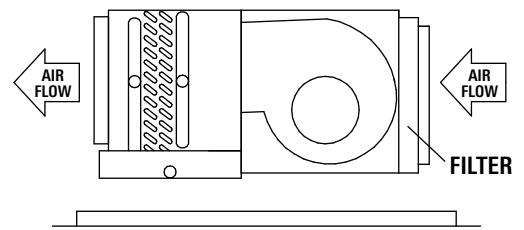

THHP REAR RETURN

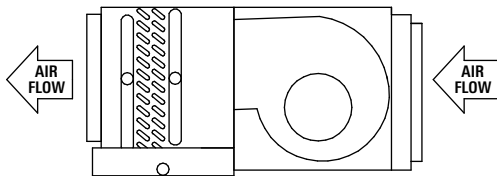

THHP BOTTOM RETURN W/BOTTOM CEILING PANEL

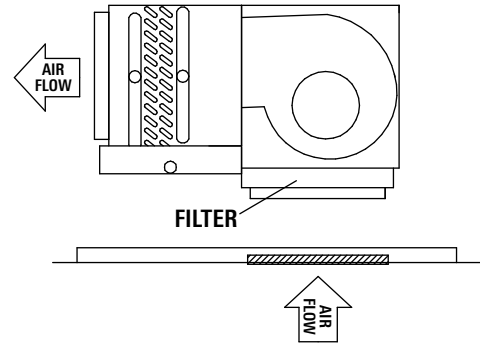

THHP BOTTOM RETURN WITH TELESCOPING BOTTOM PANEL

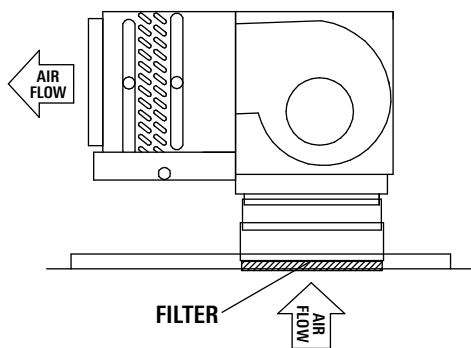

THHC FREE RETURN

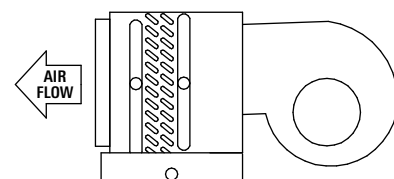

THHP MIXING BOX WITH TOP & REAR RETURN

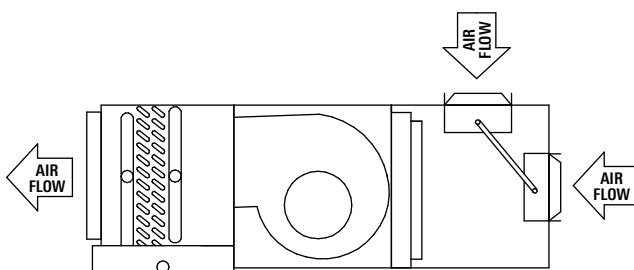

THHP MIXING BOX W/BOTTOM & REAR RETURN

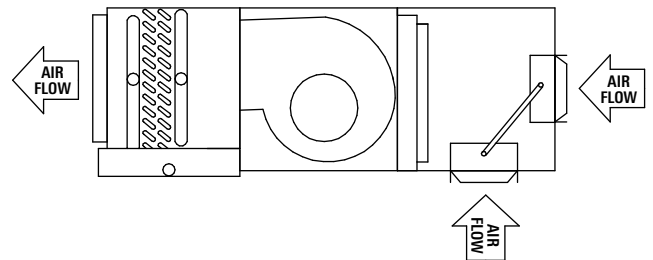

UNIT ARRANGEMENTS

THE DOUBLE DEFLECTION SUPPLY GRILLE AND DUCTED REAR RETURN

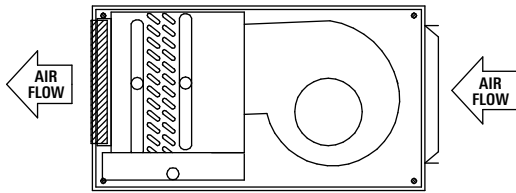

THE DUCTED SUPPLY AND SINGLE DEFLECTION REAR RETURN GRILLE

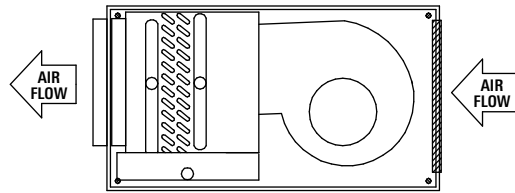

THE DOUBLE DEFLECTION SUPPLY GRILLE AND SINGLE DEFLECTION BOTTOM RETURN GRILLE

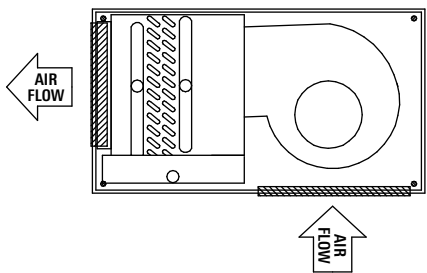

THE DUCTED SUPPLY AND DUCTED REAR RETURN

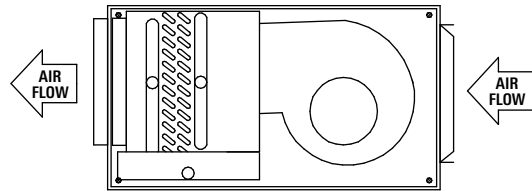

THE DOUBLE DEFLECTION SUPPLY GRILLE AND SINGLE DEFLECTION REAR RETURN GRILLE

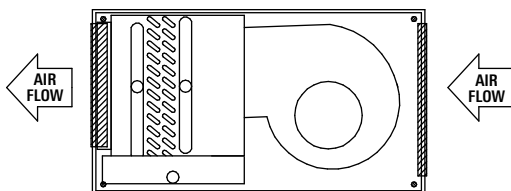

THE DUCTED SUPPLY AND SINGLE DEFLECTION BOTTOM RETURN GRILLE

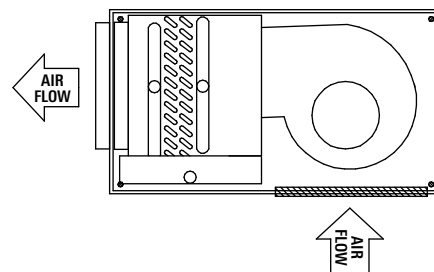

DIMENSIONAL DATA

MODEL THHP REAR RETURN EXTERNAL SPACE REQUIREMENTS

Drawings not for installation purposes. Refer to unit and size-specific submittal drawings for installation.

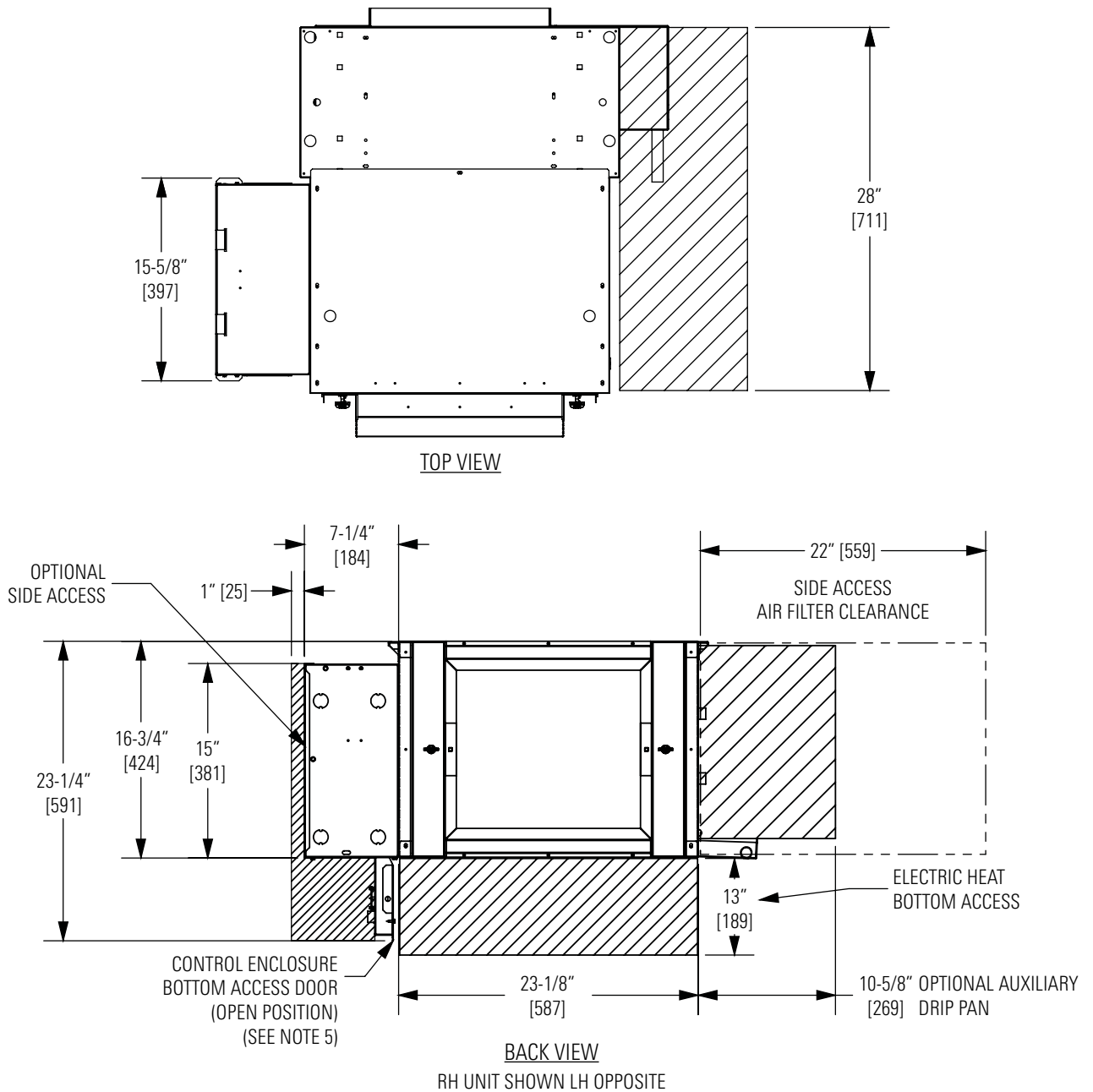

NOTES:

1. All chilled water piping that projects beyond the condensate pan or the optional auxiliary drip pan must be field insulated by others.
2. Optional Auxiliary Drip Pan (not shown) is mounted on the outlet side of the drain pan.
3. Drain pan is installed with the outlet tube(s) on cooling coil connection end of coil on 4-pipe units with optional opposite end connection.
4. Dimensions shown on this drawing apply to standard CW and HW valve packages. Refer to the Piping Package Catalog for valve package code details. Contact factory for details on valve packages using non-standard or customer furnished components.

DIMENSIONAL DATA

MODEL THHP BOTTOM RETURN EXTERNAL SPACE REQUIREMENTS

Drawings not for installation purposes. Refer to unit and size-specific submittal drawings for installation.

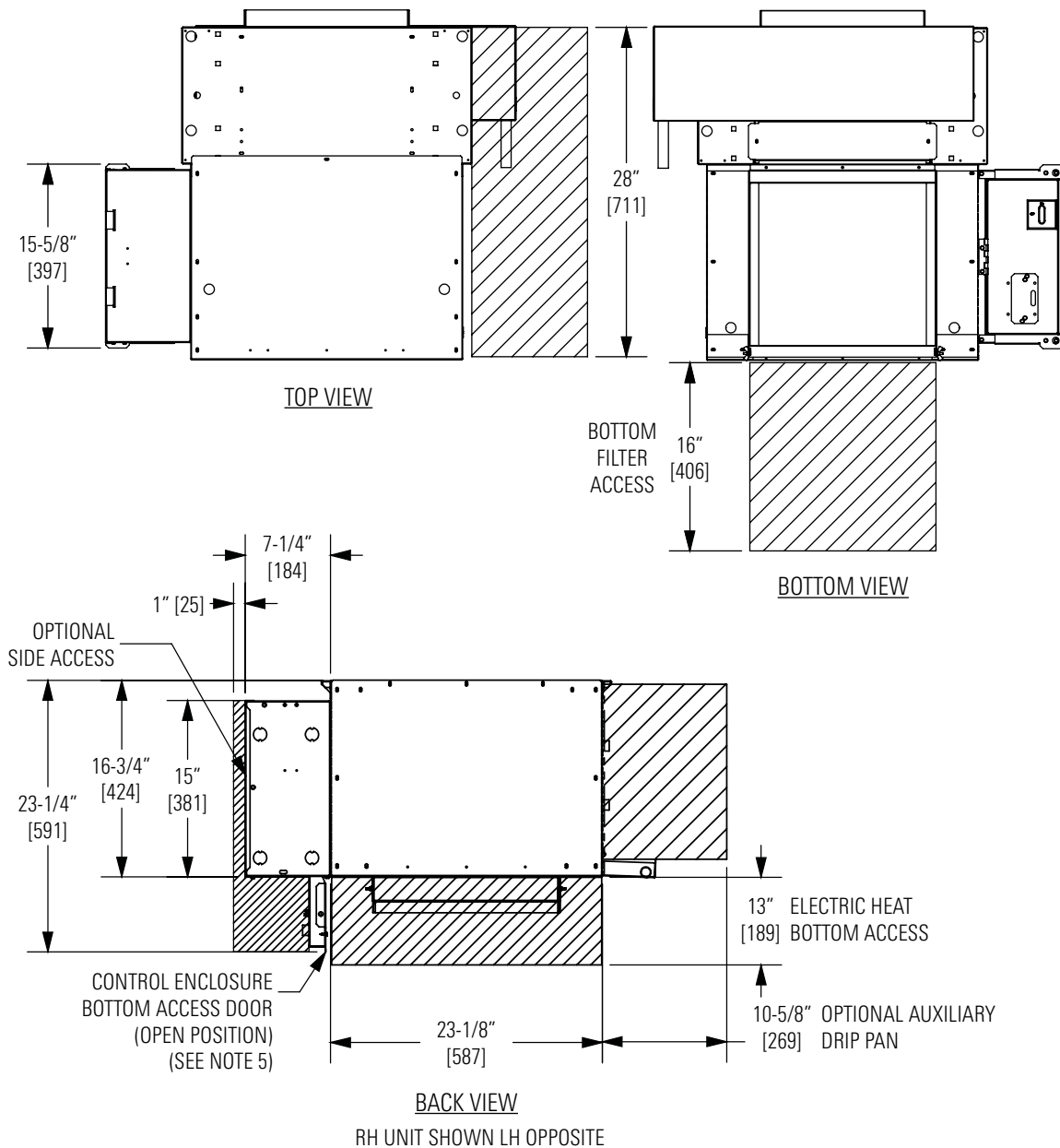

NOTES:

1. All chilled water piping that projects beyond the condensate pan or the optional auxiliary drip pan must be field insulated by others.
2. Optional Auxiliary Drip Pan (not shown) is mounted on the outlet side of the drain pan.
3. Drain pan is installed with the outlet tube(s) on cooling coil connection end of coil on 4-pipe units with optional opposite end connection.
4. Dimensions shown on this drawing apply to standard CW and HW valve packages. Refer to the Piping Package Catalog for valve package code details. Contact factory for details on valve packages using non-standard or customer furnished components.
5. Provide sufficient clearance to access electrical components and comply with all applicable codes and ordinances.

DIMENSIONAL DATA

MODEL THHP WITH MIXING BOX EXTERNAL SPACE REQUIREMENTS

Drawings not for installation purposes. Refer to unit and size-specific submittal drawings for installation.

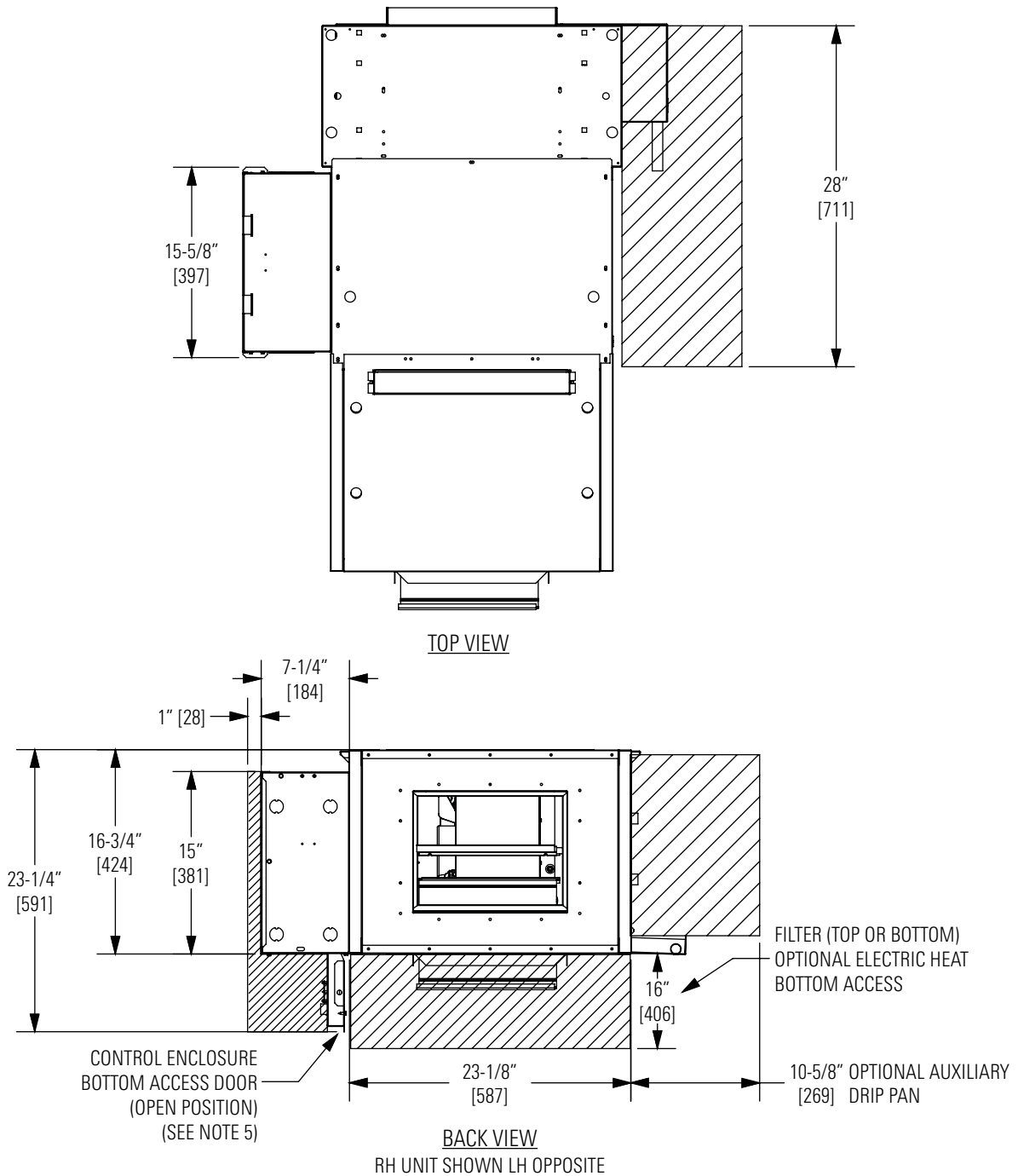

NOTES:

1. All chilled water piping that projects beyond the condensate pan or the optional auxiliary drip pan must be field insulated by others.
2. Optional Auxiliary Drip Pan (not shown) is mounted on the outlet side of the drain pan.
3. Drain pan is installed with the outlet tube(s) on cooling coil connection end of coil on 4-pipe units with optional opposite end connection.
4. Dimensions shown on this drawing apply to standard CW and HW valve packages. Refer to the Piping Package Catalog for valve package code details. Contact factory for details on valve packages using non-standard or customer furnished components.
5. Provide sufficient clearance to access electrical components and comply with all applicable codes and ordinances.

DIMENSIONAL DATA

MODEL THHE EXTERNAL SPACE REQUIREMENTS

Drawings not for installation purposes. Refer to unit and size-specific submittal drawings for installation.

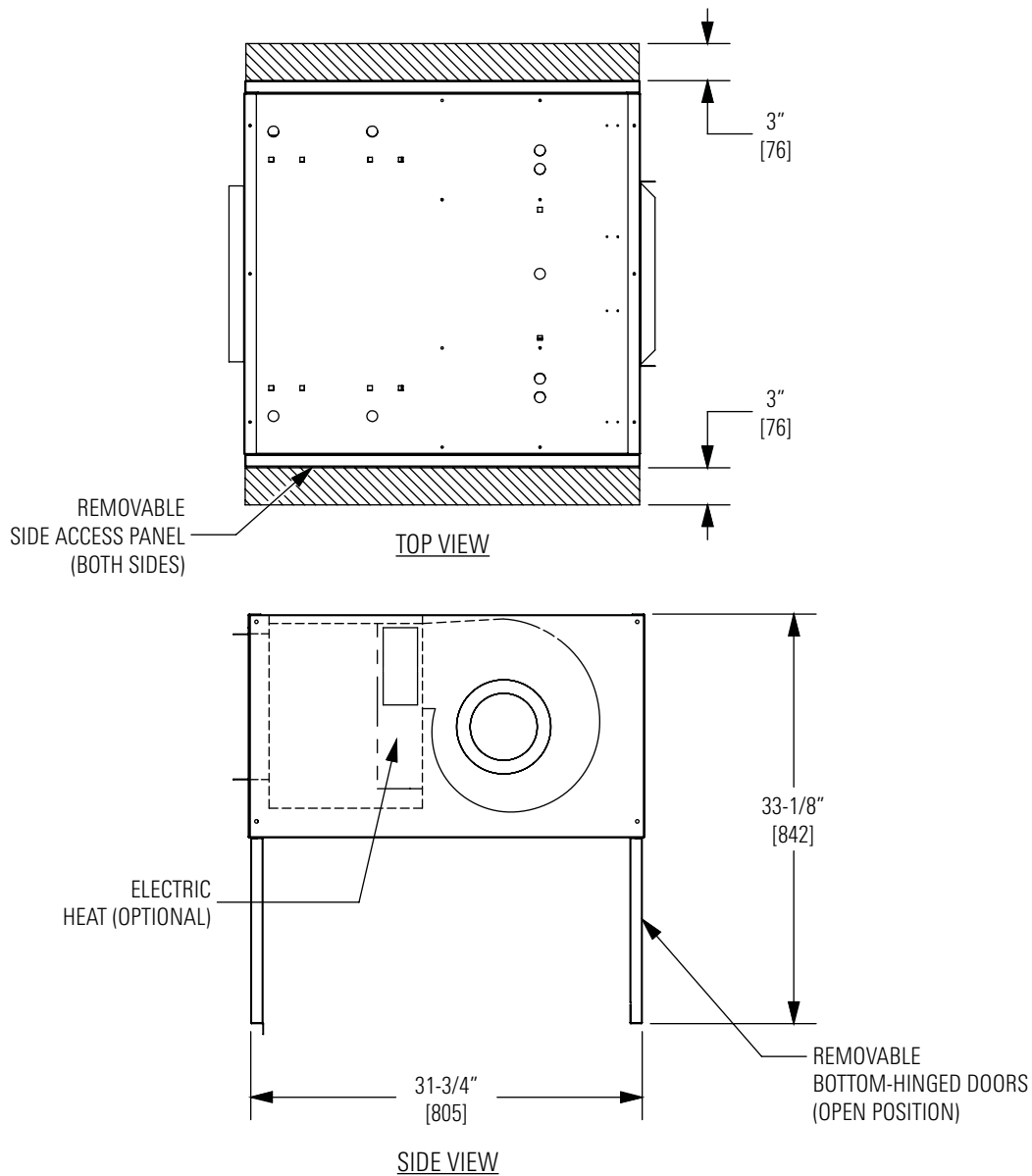

NOTES:

1. All chilled water piping that projects beyond the condensate pan or the optional auxiliary drip pan must be field insulated by others.
2. Optional Auxiliary Drip Pan (not shown) is mounted on the outlet side of the drain pan.
3. Drain pan is installed with the outlet tube(s) on cooling coil connection end of coil on 4-pipe units with optional opposite end connection.
4. Dimensions shown on this drawing apply to standard CW and HW valve packages. Refer to the Piping Package Catalog for valve package code details. Contact factory for details on valve packages using non-standard or customer furnished components.
5. Provide sufficient clearance to access electrical components and comply with all applicable codes and ordinances.

DIMENSIONAL DATA

MODEL THHC EXTERNAL SPACE REQUIREMENTS

Drawings not for installation purposes. Refer to unit and size-specific submittal drawings for installation.

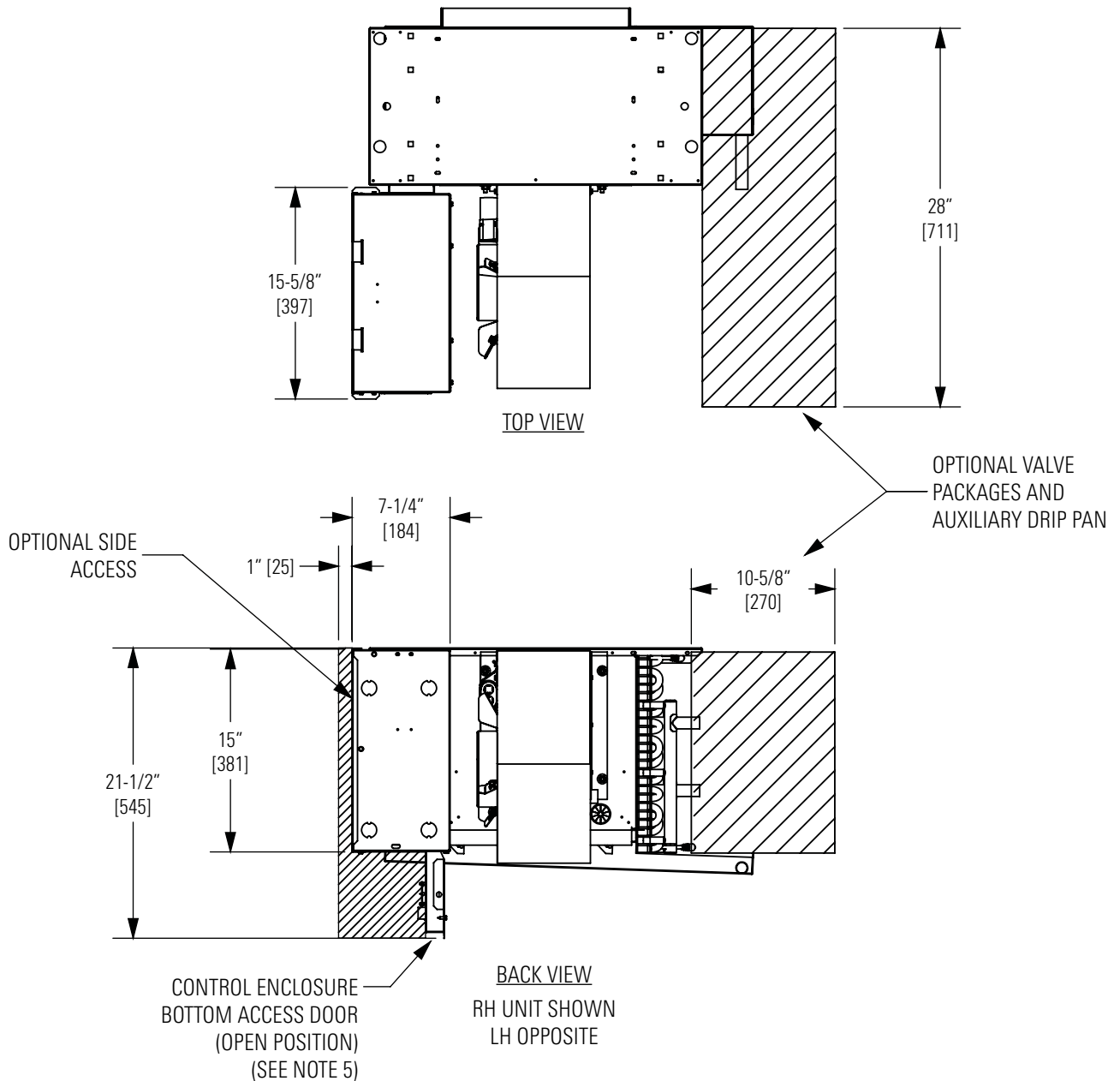

NOTES:

1. All chilled water piping that projects beyond the condensate pan or the optional auxiliary drip pan must be field insulated by others.
2. Optional Auxiliary Drip Pan (not shown) is mounted on the outlet side of the drain pan.
3. Drain pan is installed with the outlet tube(s) on cooling coil connection end of coil on 4-pipe units with optional opposite end connection.
4. Dimensions shown on this drawing apply to standard CW and HW valve packages. Refer to the Piping Package Catalog for valve package code details. Contact factory for details on valve packages using non-standard or customer furnished components.
5. Provide sufficient clearance to access electrical components and comply with all applicable codes and ordinances.

DIMENSIONAL DATA

MODEL THHP REAR RETURN 2-PIPE WITH ELECTRIC HEAT (CONTROL ENCLOSURE OPPOSITE OF HANDING)

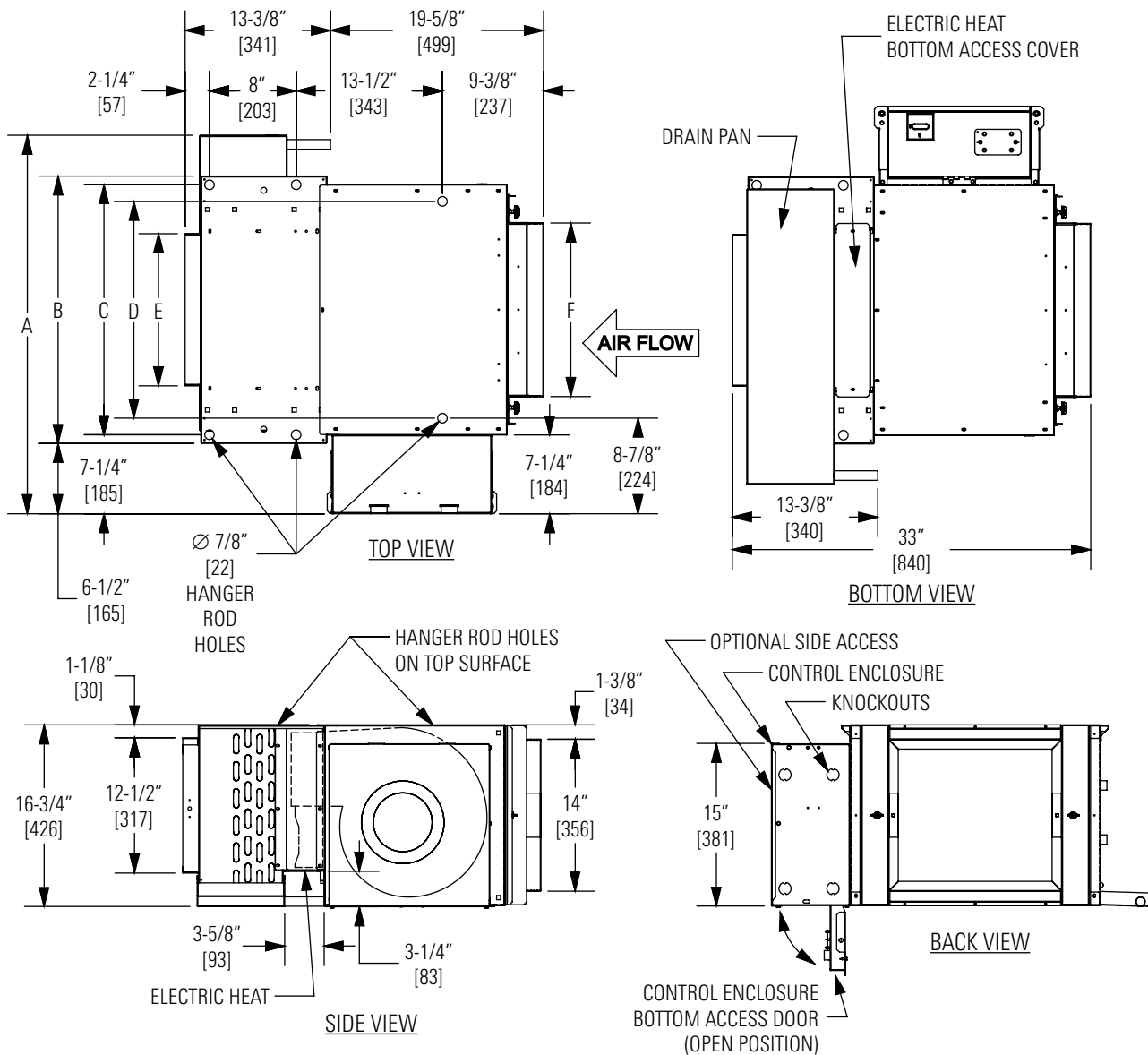

DIMENSIONS						
UNIT SIZE	A	B	C	D	E	F
06	34-7/8" [886]	24-5/8" [721]	23-1/8" [587]	20" [508]	14" [356]	16" [406]
08	39-7/8" [1013]	29-5/8" [737]	28-1/8" [714]	25" [635]	19" [483]	21" [533]
10	43-7/8" [1114]	33-5/8" [838]	32-1/8" [816]	29" [737]	23" [584]	25" [635]
12	48-7/8" [1241]	38-5/8" [965]	37-1/8" [943]	34" [864]	28" [711]	30" [762]
14	53-7/8" [1368]	43-5/8" [1092]	42-1/8" [1070]	39" [991]	33" [838]	35" [889]
16	58-7/8" [1495]	48-5/8" [1219]	47-1/8" [1197]	44" [1118]	38" [965]	40" [1016]
18	63-7/8" [1622]	53-5/8" [1346]	52-1/8" [1324]	49" [1245]	43" [1092]	45" [1143]
20	67-7/8" [1724]	57-5/8" [1448]	56-1/8" [1426]	53" [1346]	47" [1194]	49" [1245]

NOTES:

1. All dimensions in Inches [millimeters]. All dimensions $\pm 1/4"$ [6mm]. Metric values are soft conversion.
2. Right hand unit shown, Left hand unit opposite.
3. Standard control enclosure is mounted on unit side opposite cooling coil connections and includes (4) knockouts on (2) sides. Provide sufficient clearance to access electrical controls and comply with applicable codes and ordinances.

DIMENSIONAL DATA

MODEL THHP REAR RETURN 2-PIPE WITH ELECTRIC HEAT (CONTROL ENCLOSURE SAME SIDE OF HANDING)

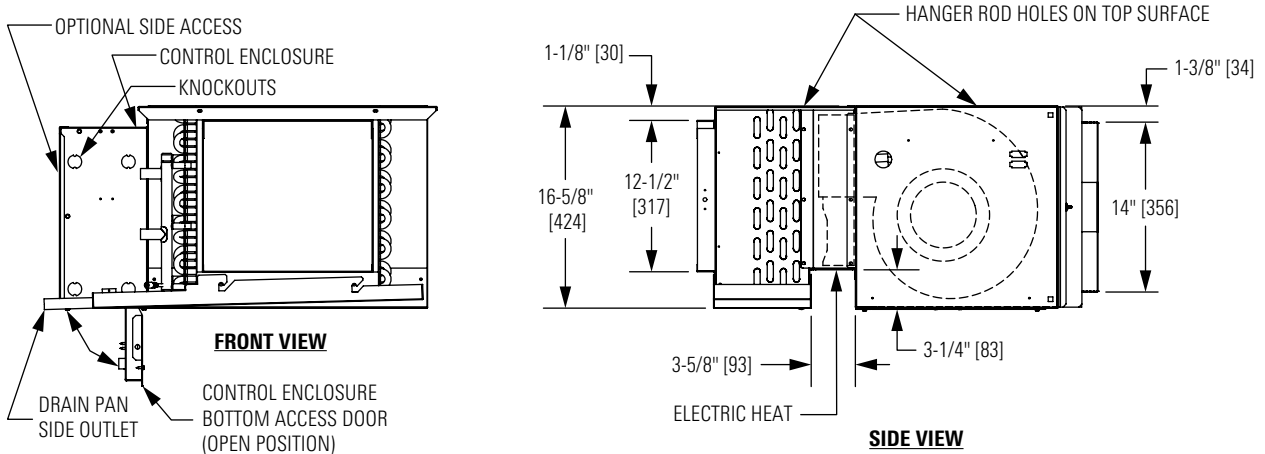
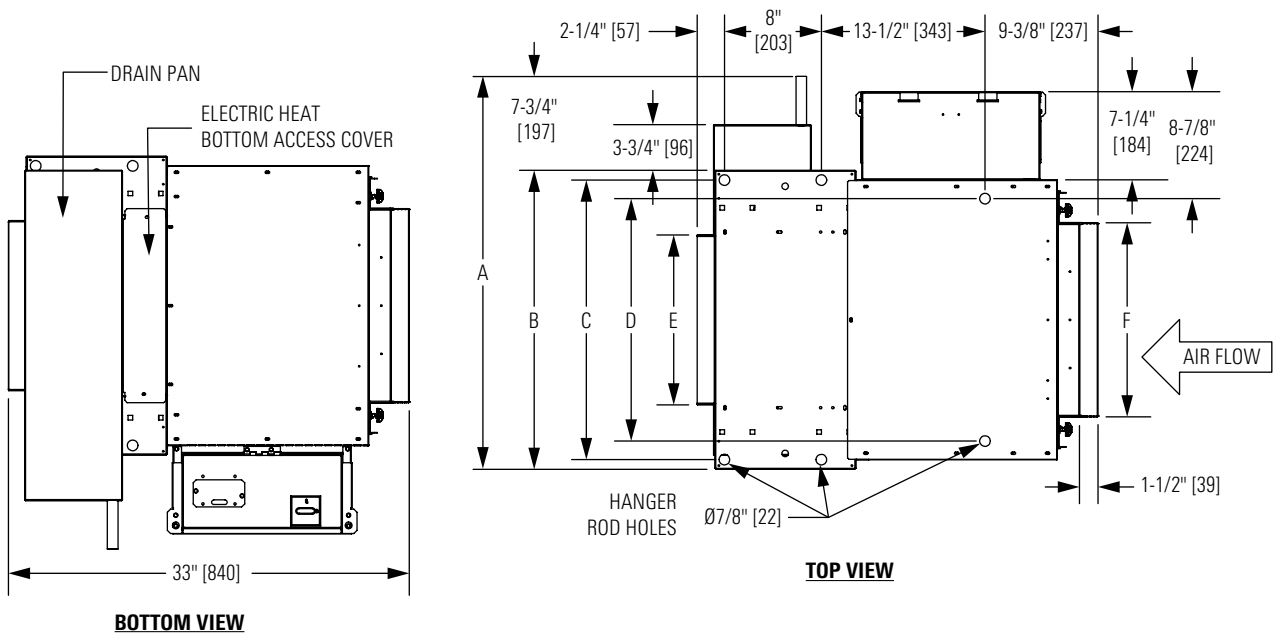

DIMENSIONS						
UNIT SIZE	A	B	C	D	E	F
06	34-7/8" [886]	24-5/8" [721]	23-1/8" [587]	20" [508]	14" [356]	16" [406]
08	39-7/8" [1013]	29-5/8" [737]	28-1/8" [714]	25" [635]	19" [483]	21" [533]
10	43-7/8" [1114]	33-5/8" [838]	32-1/8" [816]	29" [737]	23" [584]	25" [635]
12	48-7/8" [1241]	38-5/8" [965]	37-1/8" [943]	34" [864]	28" [711]	30" [762]
14	53-7/8" [1368]	43-5/8" [1092]	42-1/8" [1070]	39" [991]	33" [838]	35" [889]
16	58-7/8" [1495]	48-5/8" [1219]	47-1/8" [1197]	44" [1118]	38" [965]	40" [1016]
18	63-7/8" [1622]	53-5/8" [1346]	52-1/8" [1324]	49" [1245]	43" [1092]	45" [1143]
20	67-7/8" [1724]	57-5/8" [1448]	56-1/8" [1426]	53" [1346]	47" [1194]	49" [1245]

NOTES:

1. All dimensions in Inches [millimeters]. All dimensions ±1/4" [6mm]. Metric values are soft conversion.
2. Right hand unit shown, Left hand unit opposite.
3. Standard control enclosure is mounted on unit side opposite cooling coil connections and includes (4) knockouts on (2) sides. Provide sufficient clearance to access electrical controls and comply with applicable codes and ordinances.

DIMENSIONAL DATA

MODEL THHP REAR RETURN 2-PIPE OR 4-PIPE W/O ELECTRIC HEAT

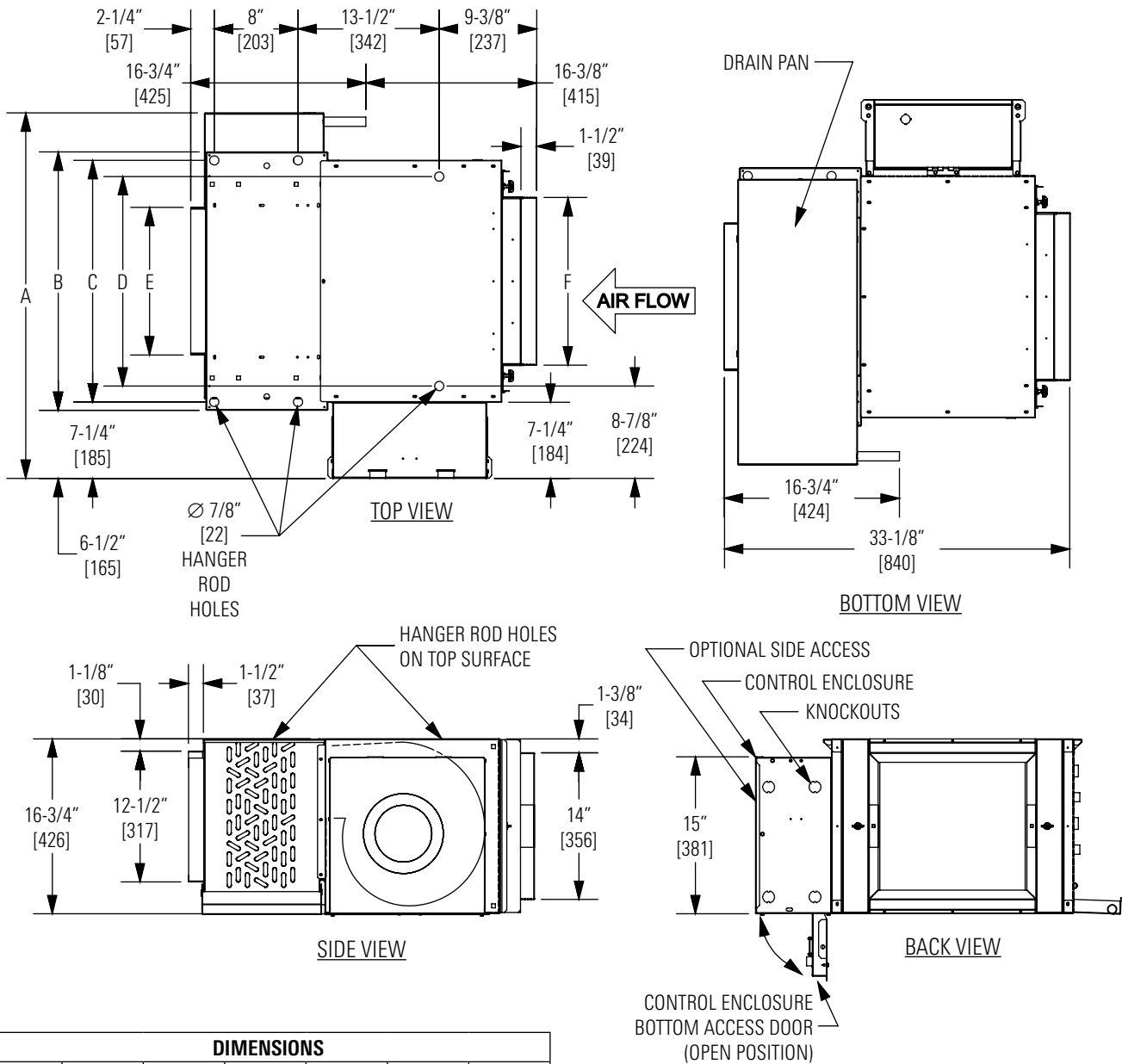

DIMENSIONS						
UNIT SIZE	A	B	C	D	E	F
06	34-7/8" [886]	24-5/8" [721]	23-1/8" [587]	20" [508]	14" [356]	16" [406]
08	39-7/8" [1013]	29-5/8" [737]	28-1/8" [714]	25" [635]	19" [483]	21" [533]
10	43-7/8" [1114]	33-5/8" [838]	32-1/8" [816]	29" [737]	23" [584]	25" [635]
12	48-7/8" [1241]	38-5/8" [965]	37-1/8" [943]	34" [864]	28" [711]	30" [762]
14	53-7/8" [1368]	43-5/8" [1092]	42-1/8" [1070]	39" [991]	33" [838]	35" [889]
16	58-7/8" [1495]	48-5/8" [1219]	47-1/8" [1197]	44" [1118]	38" [965]	40" [1016]
18	63-7/8" [1622]	53-5/8" [1346]	52-1/8" [1324]	49" [1245]	43" [1092]	45" [1143]
20	67-7/8" [1724]	57-5/8" [1448]	56-1/8" [1426]	53" [1346]	47" [1194]	49" [1245]

NOTES:

1. All dimensions in Inches [millimeters]. All dimensions ±1/4" [6mm]. Metric values are soft conversion.
2. Right hand unit shown, Left hand unit opposite.
3. Standard control enclosure is mounted on unit side opposite cooling coil connections and includes (4) knockouts on (2) sides. Provide sufficient clearance to access electrical controls and comply with applicable codes and ordinances.

DIMENSIONAL DATA

MODEL THHP BOTTOM RETURN 2-PIPE WITH ELECTRIC HEAT

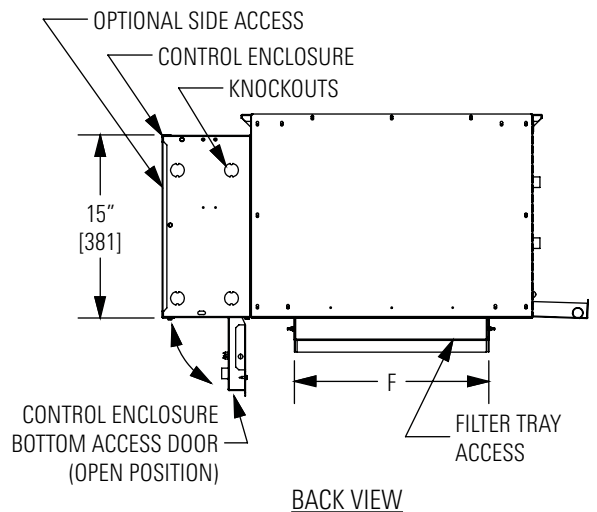
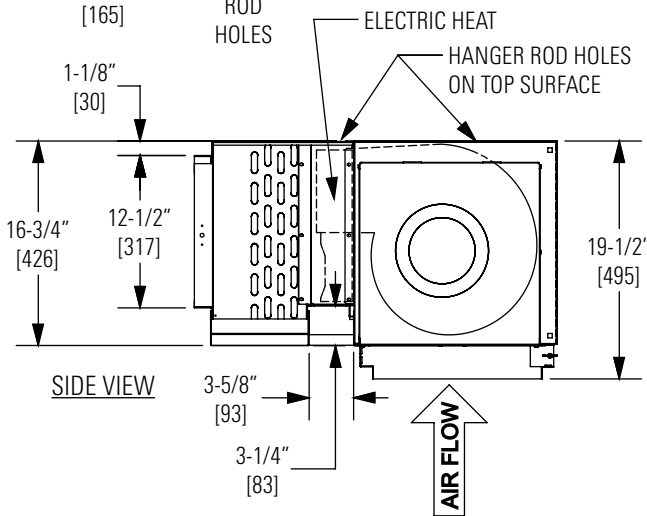
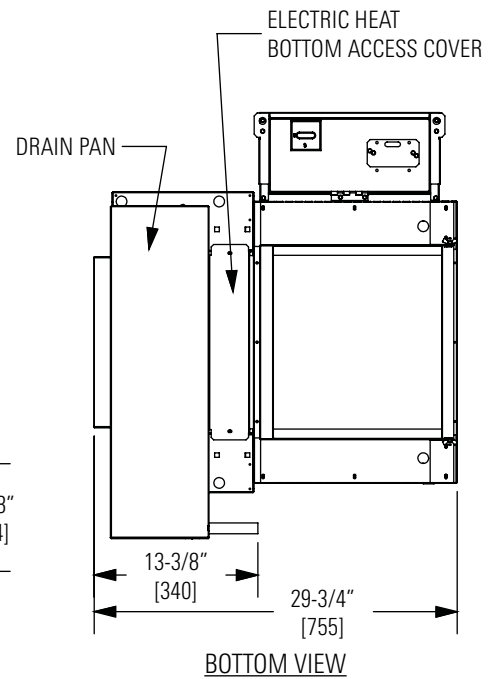
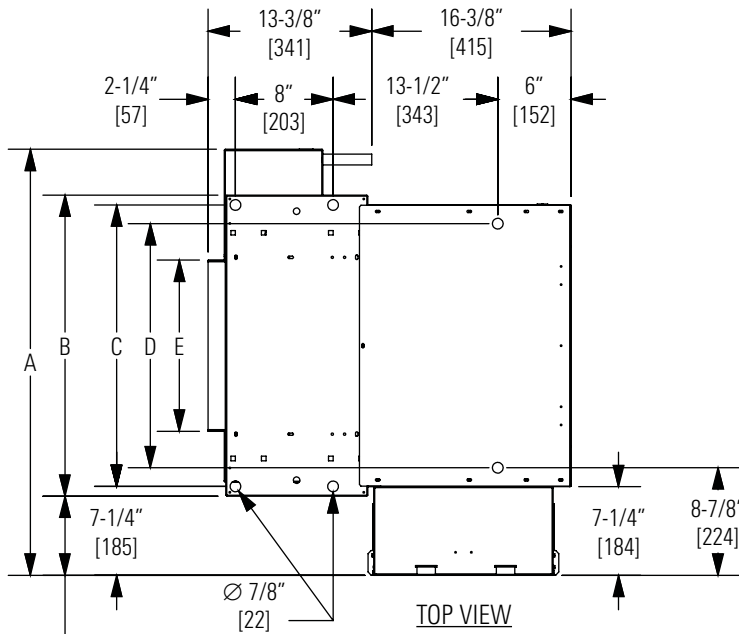

DIMENSIONS						
UNIT SIZE	A	B	C	D	E	F
06	34-7/8" [886]	24-5/8" [721]	23-1/8" [587]	20" [508]	14" [356]	16" [406]
08	39-7/8" [1013]	29-5/8" [737]	28-1/8" [714]	25" [635]	19" [483]	21" [533]
10	43-7/8" [1114]	33-5/8" [838]	32-1/8" [816]	29" [737]	23" [584]	25" [635]
12	48-7/8" [1241]	38-5/8" [965]	37-1/8" [943]	34" [864]	28" [711]	30" [762]
14	53-7/8" [1368]	43-5/8" [1092]	42-1/8" [1070]	39" [991]	33" [838]	35" [889]
16	58-7/8" [1495]	48-5/8" [1219]	47-1/8" [1197]	44" [1118]	38" [965]	40" [1016]
18	63-7/8" [1622]	53-5/8" [1346]	52-1/8" [1324]	49" [1245]	43" [1092]	45" [1143]
20	67-7/8" [1724]	57-5/8" [1448]	56-1/8" [1426]	53" [1346]	47" [1194]	49" [1245]

NOTES:

1. All dimensions in Inches [millimeters]. All dimensions $\pm 1/4"$ [6mm]. Metric values are soft conversion.
2. Right hand unit shown, Left hand unit opposite.
3. Standard control enclosure is mounted on unit side opposite cooling coil connections and includes (4) knockouts on (2) sides. Provide sufficient clearance to access electrical controls and comply with applicable codes and ordinances.

DIMENSIONAL DATA

MODEL THHP BOTTOM RETURN 2-PIPE OR 4-PIPE W/O ELECTRIC HEAT

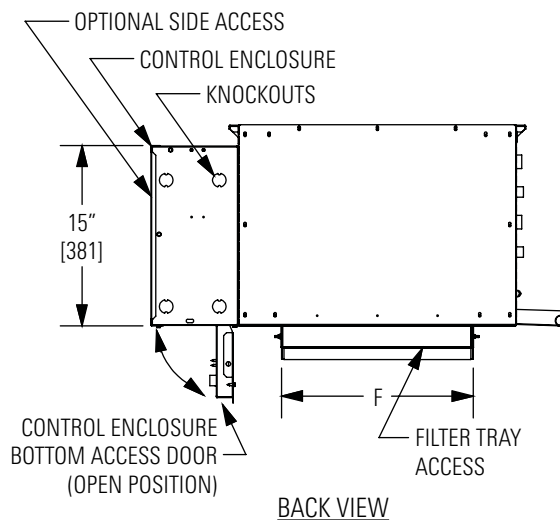
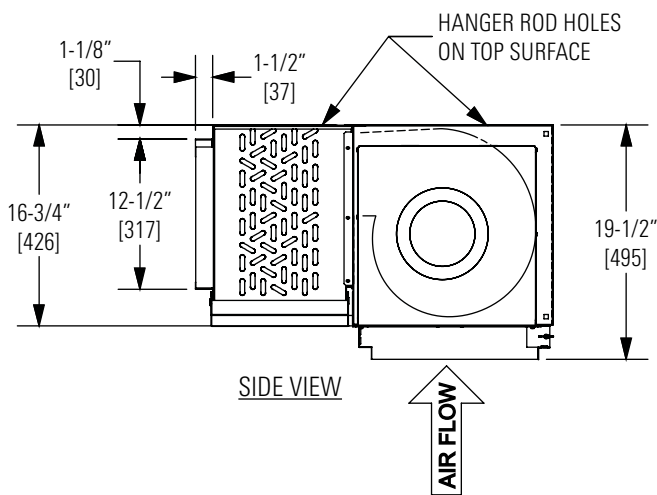
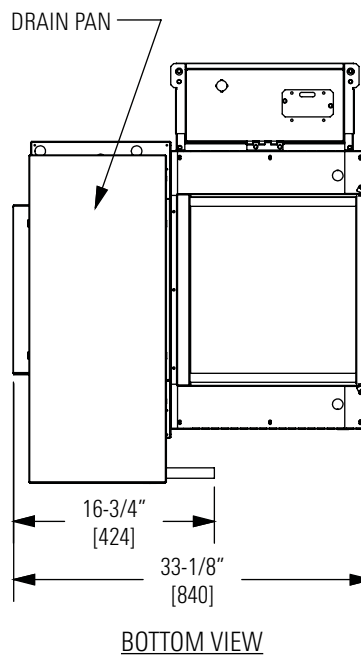
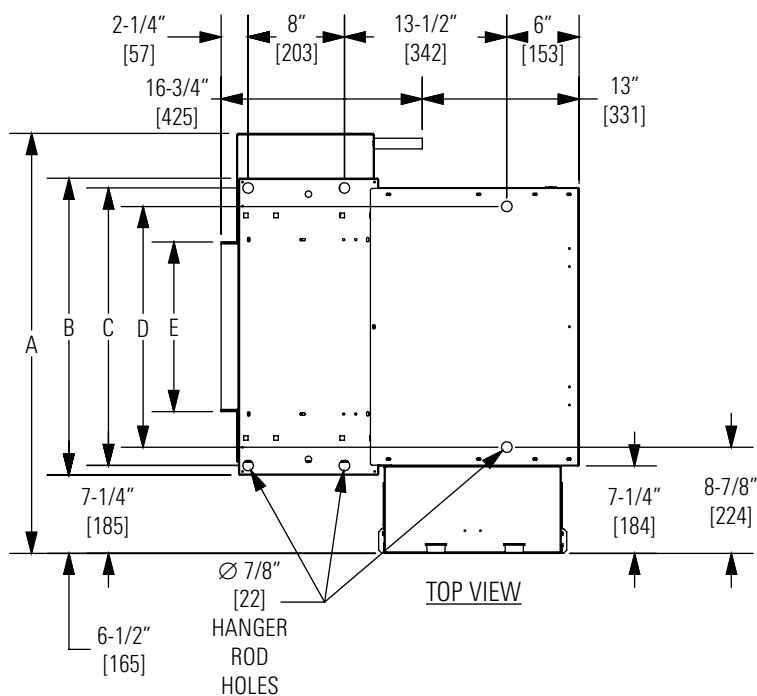

DIMENSIONS						
UNIT SIZE	A	B	C	D	E	F
06	34-7/8" [886]	24-5/8" [721]	23-1/8" [587]	20" [508]	14" [356]	16" [406]
08	39-7/8" [1013]	29-5/8" [737]	28-1/8" [714]	25" [635]	19" [483]	21" [533]
10	43-7/8" [1114]	33-5/8" [838]	32-1/8" [816]	29" [737]	23" [584]	25" [635]
12	48-7/8" [1241]	38-5/8" [965]	37-1/8" [943]	34" [864]	28" [711]	30" [762]
14	53-7/8" [1368]	43-5/8" [1092]	42-1/8" [1070]	39" [991]	33" [838]	35" [889]
16	58-7/8" [1495]	48-5/8" [1219]	47-1/8" [1197]	44" [1118]	38" [965]	40" [1016]
18	63-7/8" [1622]	53-5/8" [1346]	52-1/8" [1324]	49" [1245]	43" [1092]	45" [1143]
20	67-7/8" [1724]	57-5/8" [1448]	56-1/8" [1426]	53" [1346]	47" [1194]	49" [1245]

NOTES:

1. All dimensions in Inches [millimeters]. All dimensions $\pm 1/4"$ [6mm]. Metric values are soft conversion.
2. Right hand unit shown, Left hand unit opposite.
3. Standard control enclosure is mounted on unit side opposite cooling coil connections and includes (4) knockouts on (2) sides. Provide sufficient clearance to access electrical controls and comply with applicable codes and ordinances.

DIMENSIONAL DATA

MODEL THHP WITH ELECTRIC HEAT & MIXING BOX

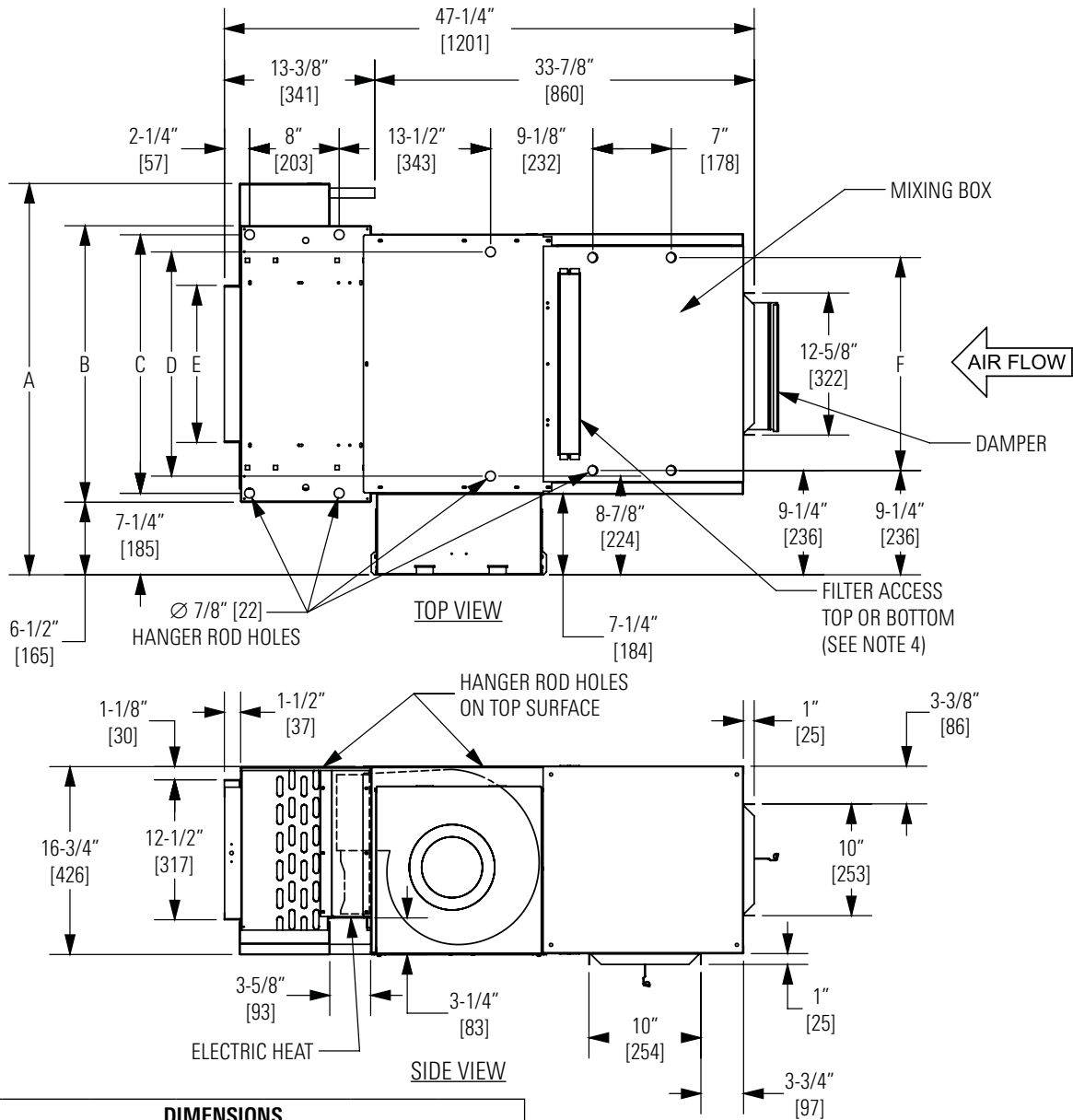

DIMENSIONS						
UNIT SIZE	A	B	C	D	E	F
06	34-7/8" [886]	24-5/8" [721]	23-1/8" [587]	20" [508]	14" [356]	19" [483]
08	39-7/8" [1013]	29-5/8" [737]	28-1/8" [714]	25" [635]	19" [483]	24" [610]
10	43-7/8" [1114]	33-5/8" [838]	32-1/8" [816]	29" [737]	23" [584]	28" [711]
12	48-7/8" [1241]	38-5/8" [965]	37-1/8" [943]	34" [864]	28" [711]	33" [838]
14	53-7/8" [1368]	43-5/8" [1092]	42-1/8" [1070]	39" [991]	33" [838]	38" [965]
16	58-7/8" [1495]	48-5/8" [1219]	47-1/8" [1197]	44" [1118]	38" [965]	43" [1092]
18	63-7/8" [1622]	53-5/8" [1346]	52-1/8" [1324]	49" [1245]	43" [1092]	48" [1219]
20	67-7/8" [1724]	57-5/8" [1448]	56-1/8" [1426]	53" [1346]	47" [1194]	52" [1321]

NOTES:

1. All dimensions in Inches [millimeters]. All dimensions $\pm 1/4"$ [6mm]. Metric values are soft conversion.
2. Right hand unit shown, Left hand unit opposite.
3. Standard control enclosure is mounted on unit side opposite cooling coil connections and includes (4) knockouts on (2) sides. Provide sufficient clearance to access electrical controls and comply with applicable codes and ordinances.
4. No Side Filter Access with Mixing Box.

DIMENSIONAL DATA

MODEL THHP WITH ELECTRIC HEAT & MIXING BOX (CONT'D)

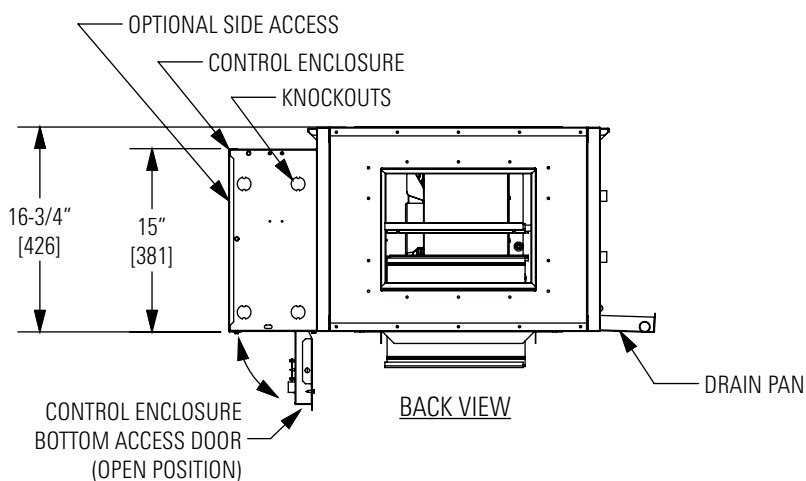
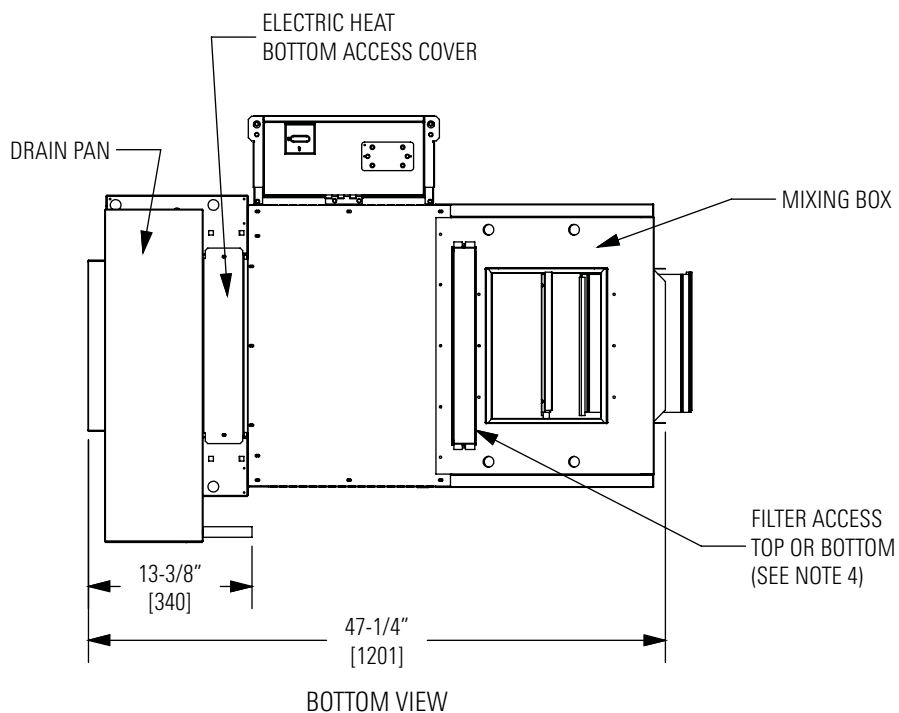

NOTES:

1. All dimensions in Inches [millimeters]. All dimensions $\pm 1/4"$ [6mm]. Metric values are soft conversion.
2. Right hand unit shown, Left hand unit opposite.
3. Standard control enclosure is mounted on unit side opposite cooling coil connections and includes (4) knockouts on (2) sides. Provide sufficient clearance to access electrical controls and comply with applicable codes and ordinances.
4. No Side Filter Access with Mixing Box.

DIMENSIONAL DATA

MODEL THHP WITH MIXING BOX, WITHOUT ELECTRIC HEAT

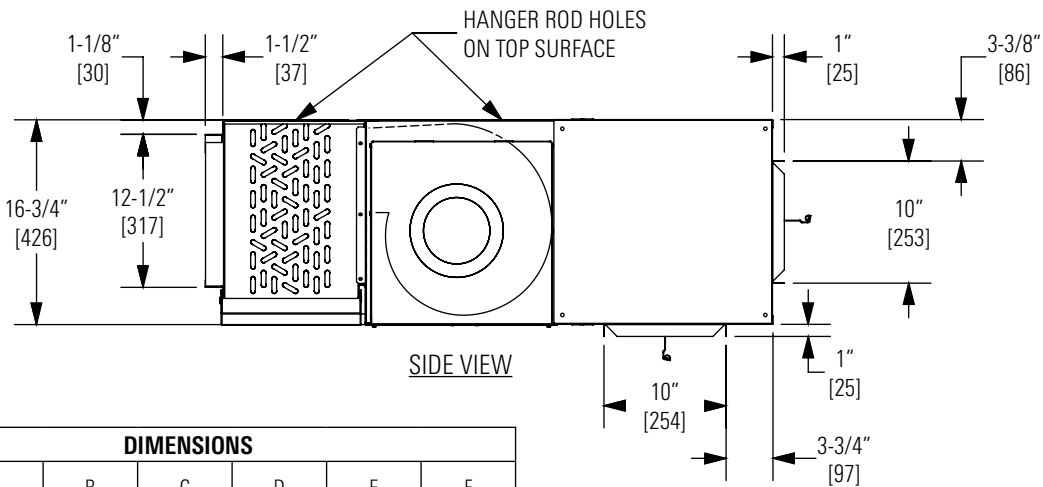
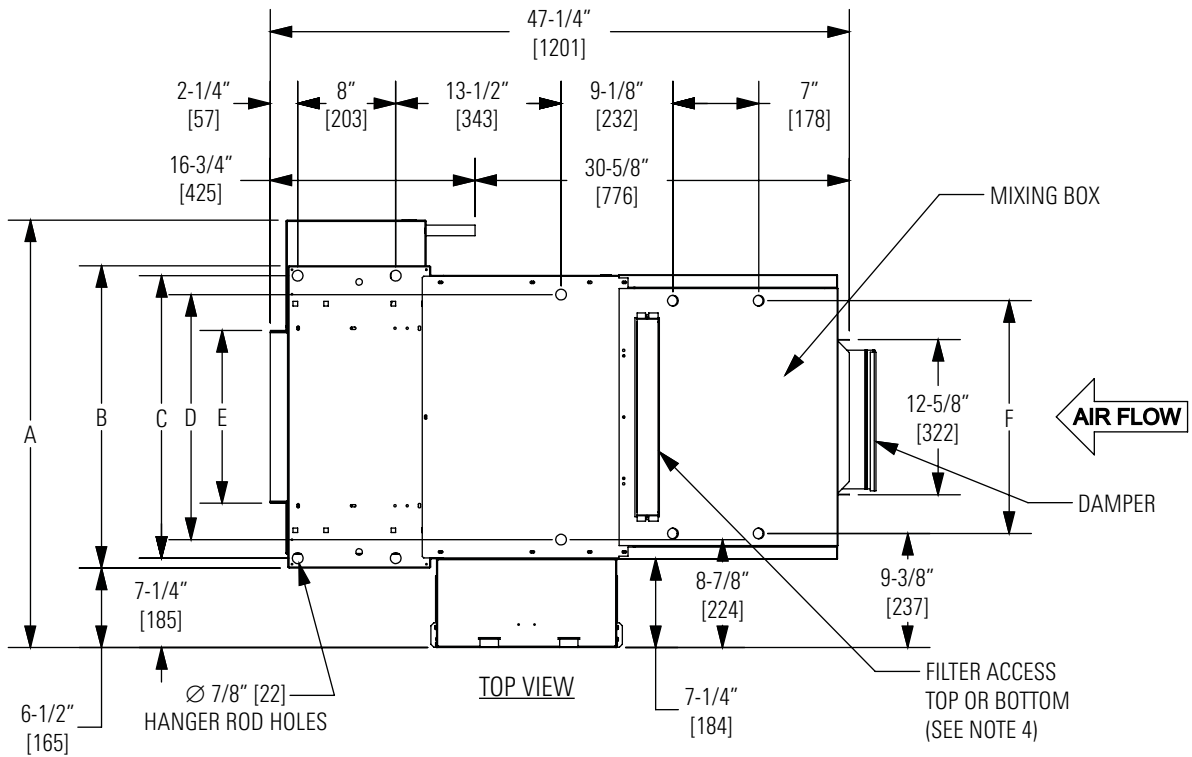

DIMENSIONS						
UNIT SIZE	A	B	C	D	E	F
06	34-7/8" [886]	24-5/8" [721]	23-1/8" [587]	20" [508]	14" [356]	19" [483]
08	39-7/8" [1013]	29-5/8" [737]	28-1/8" [714]	25" [635]	19" [483]	24" [610]
10	43-7/8" [1114]	33-5/8" [838]	32-1/8" [816]	29" [737]	23" [584]	28" [711]
12	48-7/8" [1241]	38-5/8" [965]	37-1/8" [943]	34" [864]	28" [711]	33" [838]
14	53-7/8" [1368]	43-5/8" [1092]	42-1/8" [1070]	39" [991]	33" [838]	38" [965]
16	58-7/8" [1495]	48-5/8" [1219]	47-1/8" [1197]	44" [1118]	38" [965]	43" [1092]
18	63-7/8" [1622]	53-5/8" [1346]	52-1/8" [1324]	49" [1245]	43" [1092]	48" [1219]
20	67-7/8" [1724]	57-5/8" [1448]	56-1/8" [1426]	53" [1346]	47" [1194]	52" [1321]

NOTES:

1. All dimensions in Inches [millimeters]. All dimensions $\pm 1/4"$ [6mm]. Metric values are soft conversion.
2. Right hand unit shown, Left hand unit opposite.
3. Standard control enclosure is mounted on unit side opposite cooling coil connections and includes (4) knockouts on (2) sides. Provide sufficient clearance to access electrical controls and comply with applicable codes and ordinances.
4. No Side Filter Access with Mixing Box.

DIMENSIONAL DATA

MODEL THHP WITH MIXING BOX, W/O ELECTRIC HEAT (CONT'D)

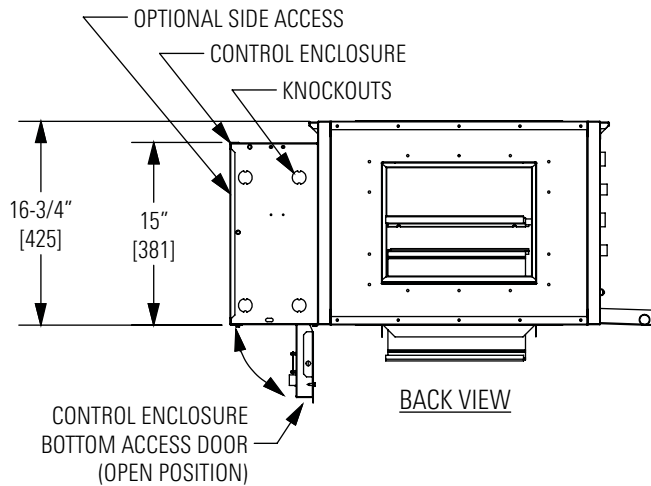
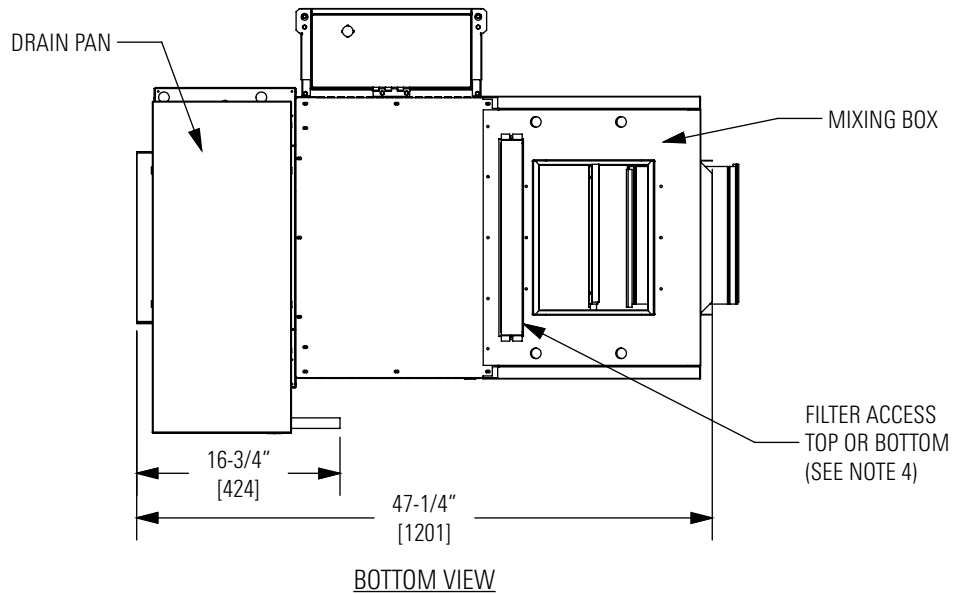

NOTES:

1. All dimensions in Inches [millimeters]. All dimensions $\pm 1/4"$ [6mm]. Metric values are soft conversion.
2. Right hand unit shown, Left hand unit opposite.
3. Standard control enclosure is mounted on unit side opposite cooling coil connections and includes (4) knockouts on (2) sides. Provide sufficient clearance to access electrical controls and comply with applicable codes and ordinances.
4. No Side Filter Access with Mixing Box.

DIMENSIONAL DATA

MODEL THHE - ALL CONFIGURATIONS

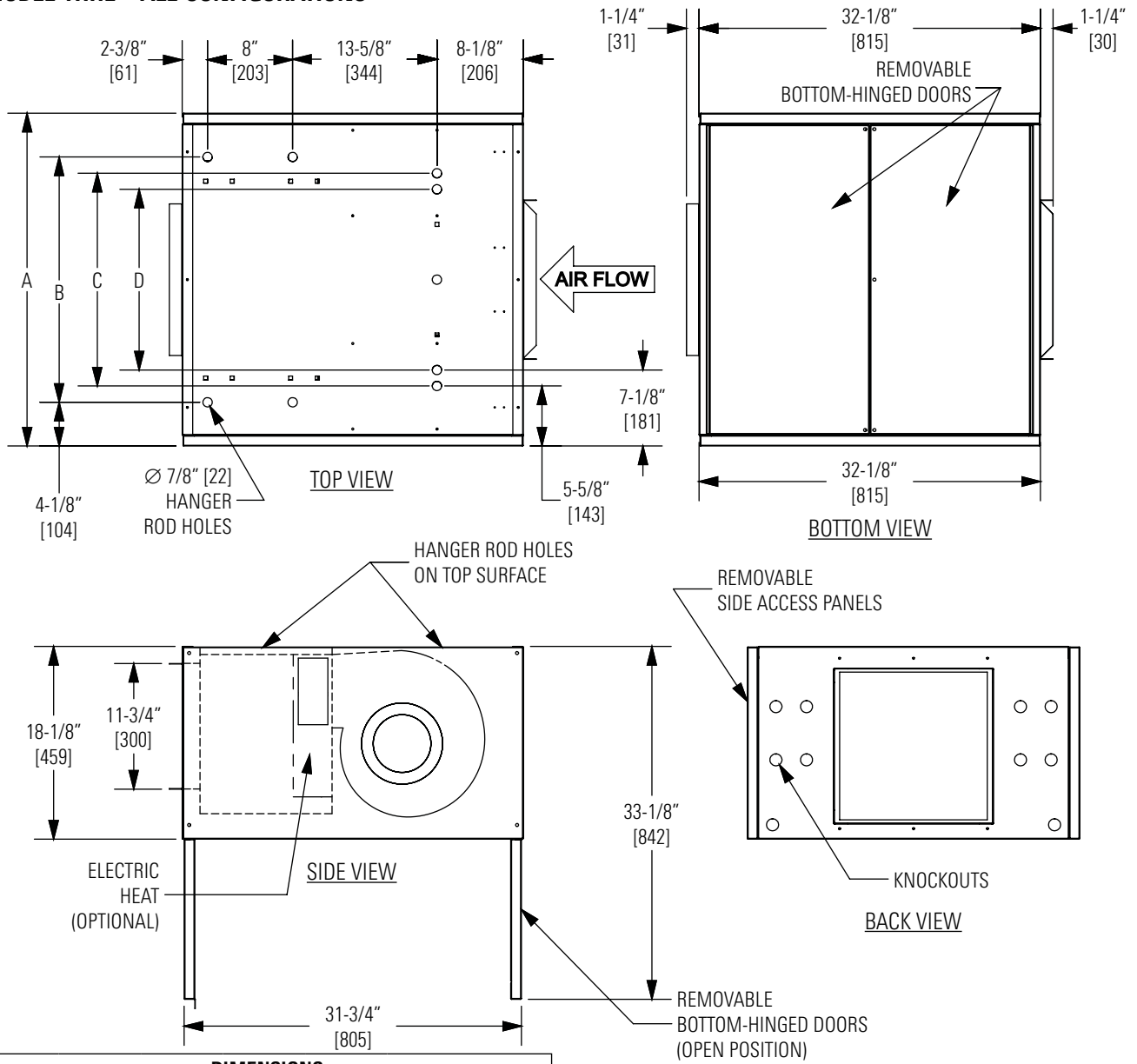

DIMENSIONS					
UNIT SIZE	A	B	C	D	A + 6.0" EXTENDED PANEL
06	31-1/4" [794]	23" [584]	20" [508]	17" [432]	37-1/4" [946]
08	36-1/4" [921]	28" [711]	25" [635]	22" [559]	42-1/4" [1073]
10	40-1/4" [1022]	32" [813]	29" [737]	26" [660]	46-1/4" [1174]
12	45-1/4" [1149]	37" [940]	34" [864]	31" [787]	51-1/4" [1302]
14	50-1/4" [1276]	42" [1067]	39" [991]	36" [914]	56-1/4" [1428]
16	55-1/4" [1403]	47" [1194]	44" [1118]	41" [1041]	61-1/4" [1556]
18	60-1/4" [1403]	52" [1321]	49" [1245]	46" [1168]	66-1/4" [1683]
20	64-1/4" [1632]	56" [1422]	53" [1346]	50" [1270]	70-1/4" [1784]

NOTES:

1. All dimensions in Inches [millimeters]. All dimensions $\pm 1/4"$ [6mm]. Metric values are soft conversion.
2. Right hand unit shown, Left hand unit opposite.
3. Standard control enclosure is mounted on unit side opposite cooling coil connections and includes (4) knockouts on (2) sides. Provide sufficient clearance to access electrical controls and comply with applicable codes and ordinances.

DIMENSIONAL DATA

MODEL THHE - ALL CONFIGURATIONS (CONT'D)

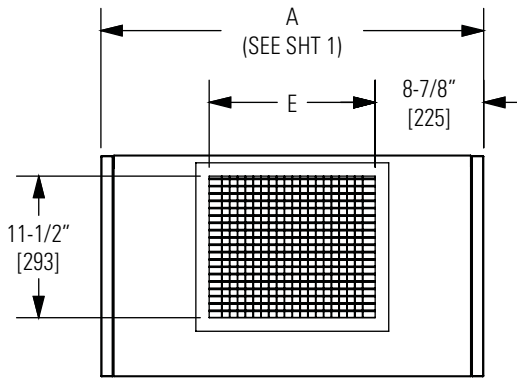

**FRONT PANEL
GRILLED SUPPLY**

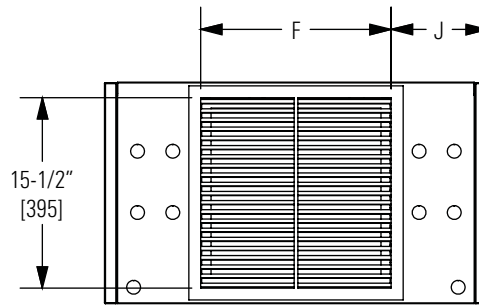

**BACK PANEL
GRILLED RETURN**

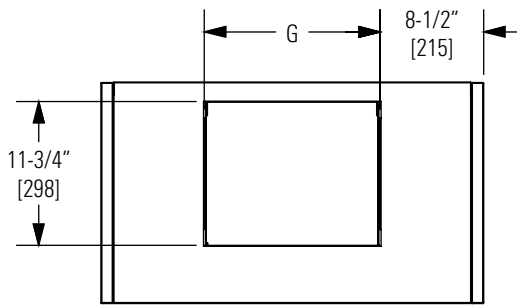

**FRONT PANEL
DUCTED SUPPLY**

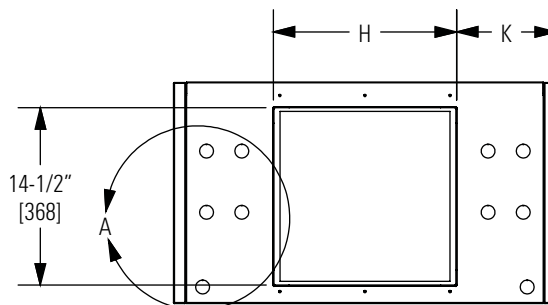

**BACK PANEL
DUCTED RETURN**

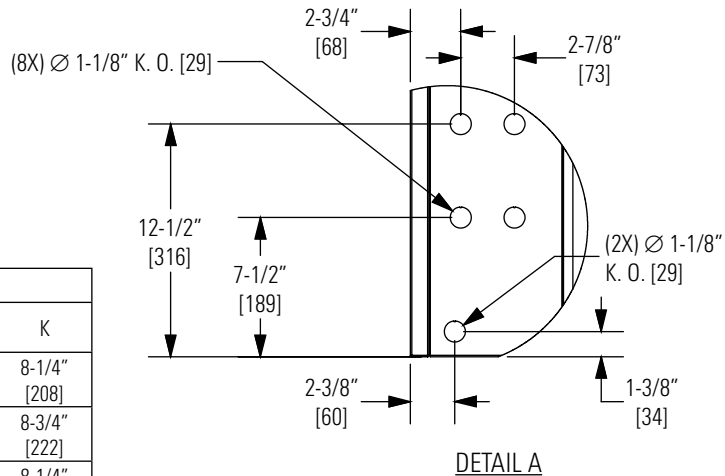

DETAIL A

DIMENSIONS						
UNIT SIZE	E	F	G	H	J	K
06	13-1/2" [344]	15-1/2" [394]	14-3/8" [365]	17" [381]	7-7/8" [200]	8-1/4" [208]
08	17-1/2" [445]	19-1/2" [495]	19-3/8" [492]	19" [483]	8-3/8" [213]	8-3/4" [222]
10	22-1/2" [572]	24-1/2" [622]	23-3/8" [594]	24" [610]	7-7/8" [200]	8-1/4" [208]
12	29-1/2" [749]	31-1/2" [800]	28-3/8" [721]	31" [787]	6-7/8" [175]	7-1/4" [184]
14	33-1/2" [851]	35-1/2" [902]	33-3/8" [848]	35" [889]	7-3/8" [187]	7-3/4" [197]
16	37-1/2" [953]	39-1/2" [1003]	38-3/8" [975]	39" [991]	7-7/8" [200]	8-1/4" [208]
18	42-1/2" [1080]	44-1/2" [1130]	43-3/8" [1102]	44" [1118]	7-7/8" [200]	8-1/4" [208]
20	47-1/2" [1207]	49-1/2" [1257]	47-3/8" [1203]	49" [1245]	7-3/8" [187]	7-3/4" [197]

NOTES:

1. All dimensions in Inches [millimeters]. All dimensions $\pm 1/4"$ [6mm]. Metric values are soft conversion.
2. Right hand unit shown, Left hand unit opposite.
3. Standard control enclosure is mounted on unit side opposite cooling coil connections and includes (4) knockouts on (2) sides. Provide sufficient clearance to access electrical controls and comply with applicable codes and ordinances.

DIMENSIONAL DATA

MODEL THHE - ALL CONFIGURATIONS (CONT'D)

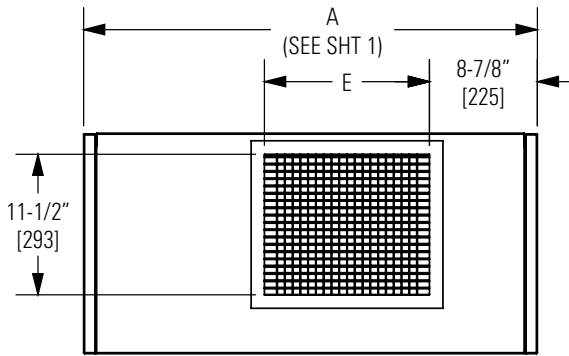

EXTENDED FRONT PANEL
GRILLED SUPPLY

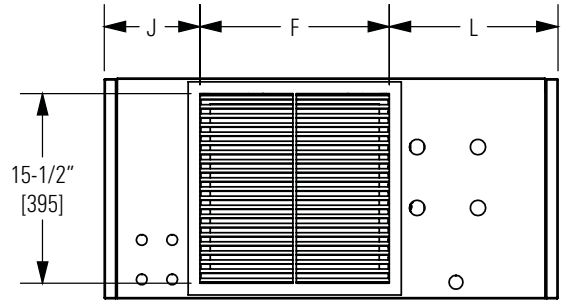

EXTENDED BACK PANEL
GRILLED SUPPLY

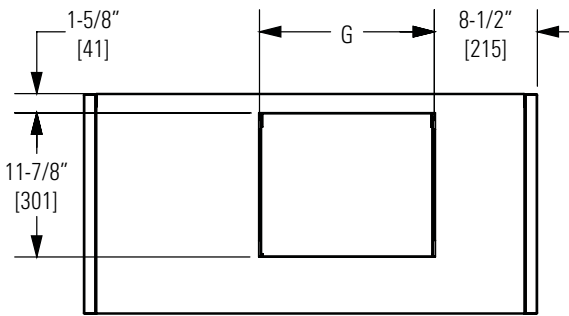

EXTENDED FRONT PANEL
DUCTED SUPPLY

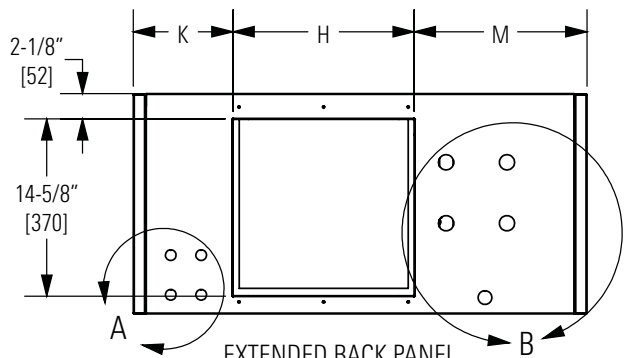

EXTENDED BACK PANEL
DUCTED SUPPLY

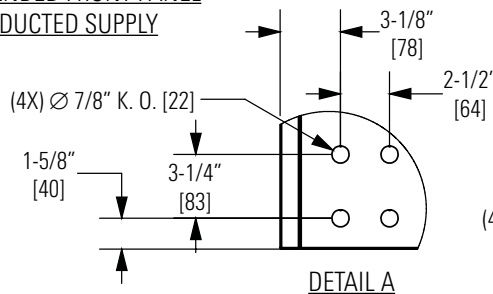

DETAIL A

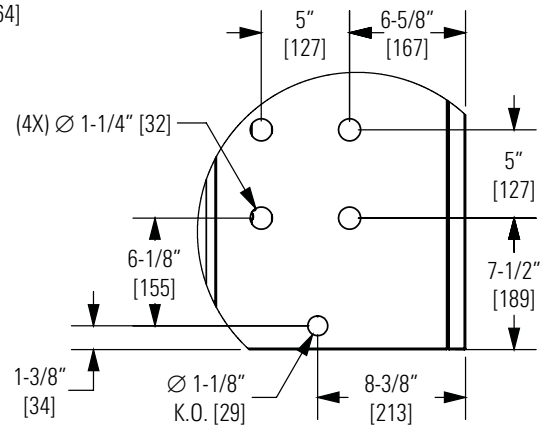

DETAIL B

DIMENSIONS								
UNIT SIZE	E	F	G	H	J	K	L	M
06	13-1/2" [344]	15-1/2" [394]	14-3/8" [365]	15" [381]	7-7/8" [200]	8-1/4" [208]	13-7/8" [352]	14-1/4" [362]
08	17-1/2" [445]	19-1/2" [495]	19-3/8" [492]	19" [483]	8-3/8" [213]	8-3/4" [222]	14-3/8" [365]	14-3/4" [375]
10	22-1/2" [572]	24-1/2" [622]	23-3/8" [594]	24" [610]	7-7/8" [200]	8-1/4" [208]	13-7/8" [352]	14-1/4" [362]
12	29-1/2" [749]	31-1/2" [800]	28-3/8" [721]	31" [787]	6-7/8" [175]	7-1/4" [184]	12-7/8" [327]	13-1/4" [337]
14	33-1/2" [851]	35-1/2" [902]	33-3/8" [848]	35" [889]	7-3/8" [187]	7-3/4" [197]	13-3/8" [340]	13-3/4" [349]
16	37-1/2" [953]	39-1/2" [1003]	38-3/8" [975]	39" [991]	7-7/8" [200]	8-1/4" [208]	13-7/8" [352]	14-1/4" [362]
18	42-1/2" [1080]	44-1/2" [1130]	43-3/8" [1102]	44" [1118]	7-7/8" [200]	8-1/4" [208]	13-7/8" [352]	14-1/4" [362]
20	47-1/2" [1207]	44-1/2" [1130]	47-3/8" [1203]	49" [1245]	9-7/8" [251]	7-3/4" [197]	15-7/8" [403]	13-3/4" [349]

NOTES:

1. All dimensions in Inches [millimeters]. All dimensions $\pm 1/4"$ [6mm]. Metric values are soft conversion.
2. Right hand unit shown, Left hand unit opposite.
3. Standard control enclosure is mounted on unit side opposite cooling coil connections and includes (4) knockouts on (2) sides. Provide sufficient clearance to access electrical controls and comply with applicable codes and ordinances.

DIMENSIONAL DATA

MODEL THHE - ALL CONFIGURATIONS (CONT'D)

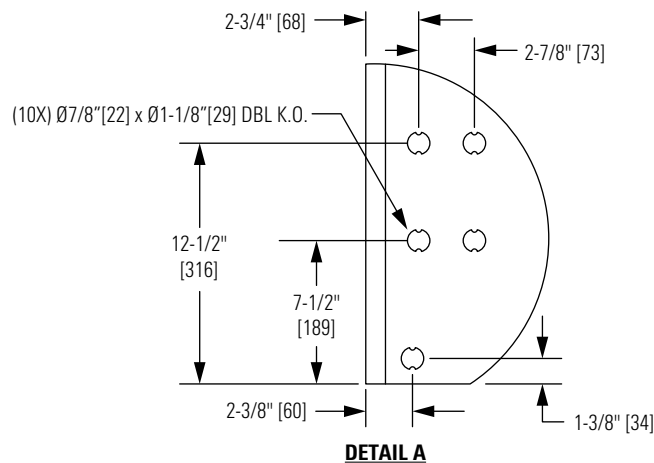
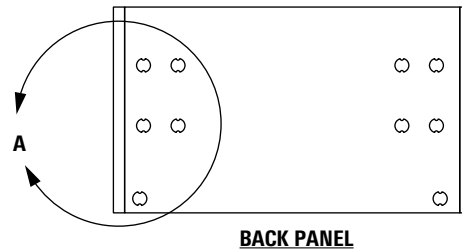
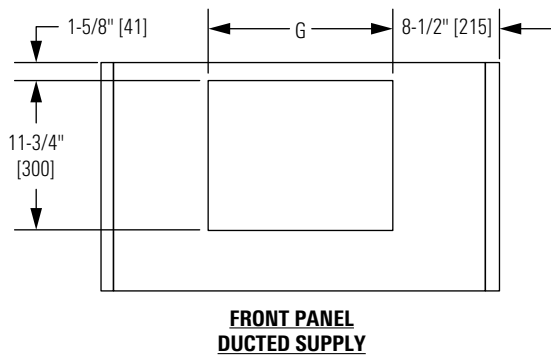
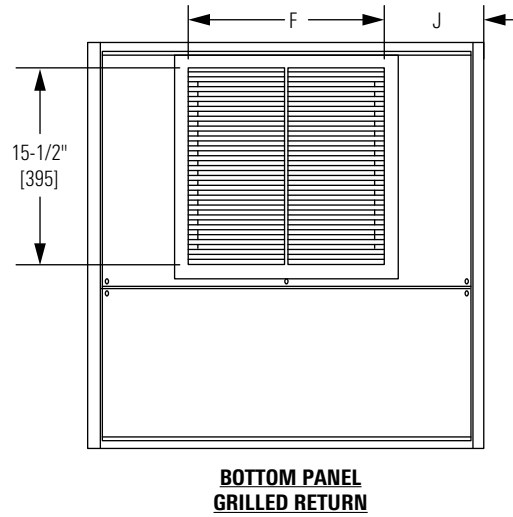
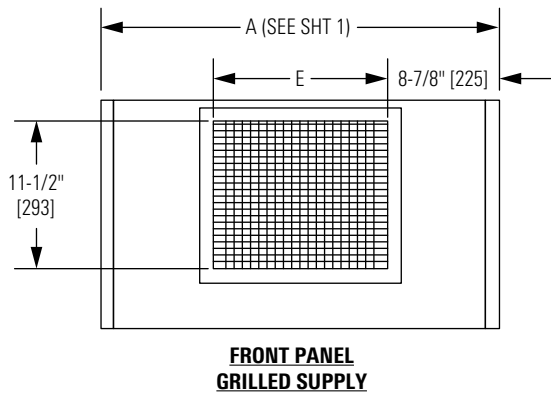

DIMENSIONS				
UNIT SIZE	E	F	G	L
06	13-1/2" [344]	15-1/2" [394]	14-3/8" [365]	7-7/8" [200]
08	17-1/2" [445]	19-1/2" [495]	19-3/8" [492]	8-3/8" [213]
10	22-1/2" [572]	24-1/2" [622]	23-3/8" [594]	7-7/8" [200]
12	29-1/2" [749]	31-1/2" [800]	28-3/8" [721]	6-7/8" [175]
14	33-1/2" [851]	35-1/2" [902]	33-3/8" [848]	7-3/8" [187]
16	37-1/2" [953]	39-1/2" [1003]	38-3/8" [975]	7-7/8" [200]
18	42-1/2" [1080]	44-1/2" [1130]	43-3/8" [1102]	7-7/8" [200]
20	47-1/2" [1207]	44-1/2" [1130]	47-3/8" [1203]	9-7/8" [251]

NOTES:

1. All dimensions in Inches [millimeters]. All dimensions $\pm 1/4"$ [6mm]. Metric values are soft conversion.
2. Right hand unit shown, Left hand unit opposite.
3. Standard control enclosure is mounted inside unit opposite cooling coil connections and includes (4) knockouts on (2) sides. Provide sufficient clearance to access electrical controls and comply with applicable codes and ordinances.

DIMENSIONAL DATA

MODEL THHE - ALL CONFIGURATIONS (CONT'D)

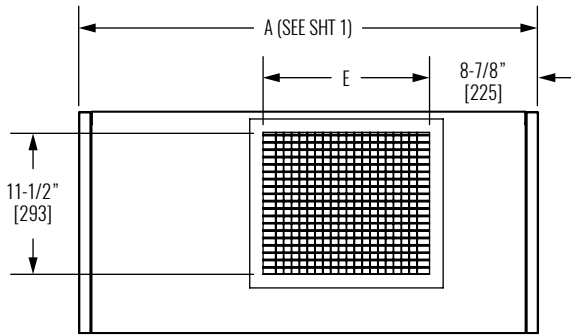

**EXTENDED FRONT PANEL
GRILLED SUPPLY**

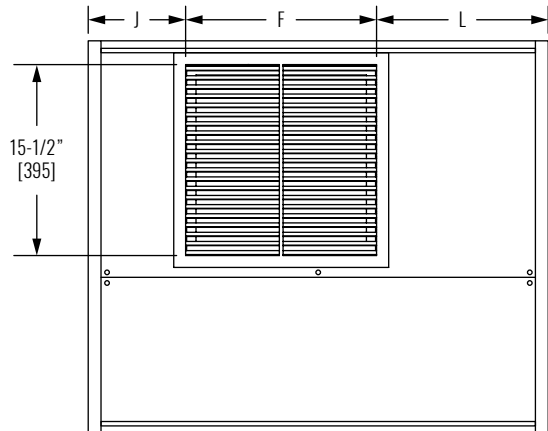

**EXTENDED BOTTOM PANEL
GRILLED RETURN**

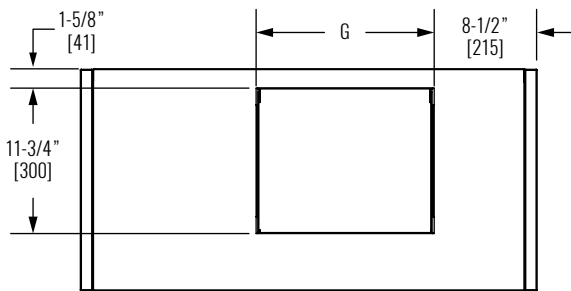

**EXTENDED FRONT PANEL
DUCTED SUPPLY**

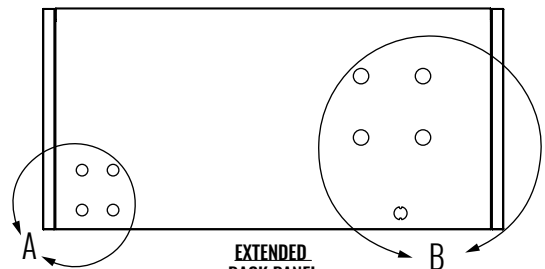

**EXTENDED
BACK PANEL**

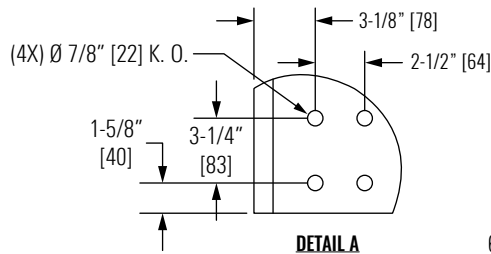

DETAIL A

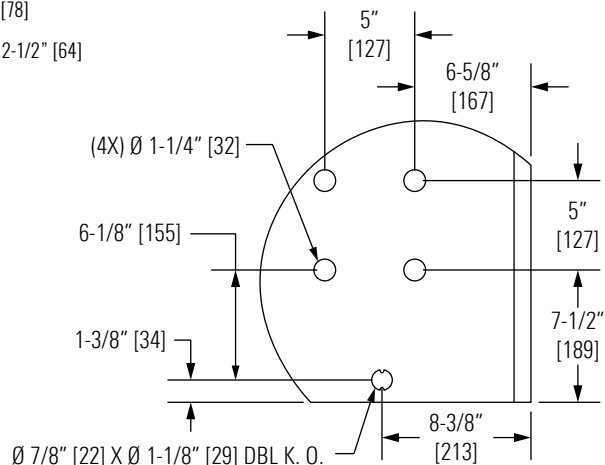

DETAIL B

DIMENSIONS								
UNIT SIZE	E	F	G	H	J	K	L	M
06	13-1/2" [344]	15-1/2" [394]	14-3/8" [365]	15" [381]	7-7/8" [200]	8-1/4" [208]	13-7/8" [352]	14-1/4" [362]
08	17-1/2" [445]	19-1/2" [495]	19-3/8" [492]	19" [483]	8-3/8" [213]	8-3/4" [222]	14-3/8" [365]	14-3/4" [375]
10	22-1/2" [572]	24-1/2" [622]	23-3/8" [594]	24" [610]	7-7/8" [200]	8-1/4" [208]	13-7/8" [352]	14-1/4" [362]
12	29-1/2" [749]	31-1/2" [800]	28-3/8" [721]	31" [787]	6-7/8" [175]	7-1/4" [184]	12-7/8" [327]	13-1/4" [337]
14	33-1/2" [851]	35-1/2" [902]	33-3/8" [848]	35" [889]	7-3/8" [187]	7-3/4" [197]	13-3/8" [340]	13-3/4" [349]
16	37-1/2" [953]	39-1/2" [1003]	38-3/8" [975]	39" [991]	7-7/8" [200]	8-1/4" [208]	13-7/8" [352]	14-1/4" [362]
18	42-1/2" [1080]	44-1/2" [1130]	43-3/8" [1102]	44" [1118]	7-7/8" [200]	8-1/4" [208]	13-7/8" [352]	14-1/4" [362]
20	47-1/2" [1207]	44-1/2" [1130]	47-3/8" [1203]	49" [1245]	9-7/8" [251]	7-3/4" [197]	15-7/8" [403]	13-3/4" [349]

NOTES:

- All dimensions in Inches [millimeters]. All dimensions $\pm 1/4"$ [6mm]. Metric values are soft conversion.
- Right hand unit shown, Left hand unit opposite.
- Standard control enclosure is mounted inside unit opposite cooling coil connections and includes (4) knockouts on (2) sides. Provide sufficient clearance to access electrical controls and comply with applicable codes and ordinances.
- Extended cabinet is only offered when 3-way valve package is selected.

DIMENSIONAL DATA

MODEL THHC

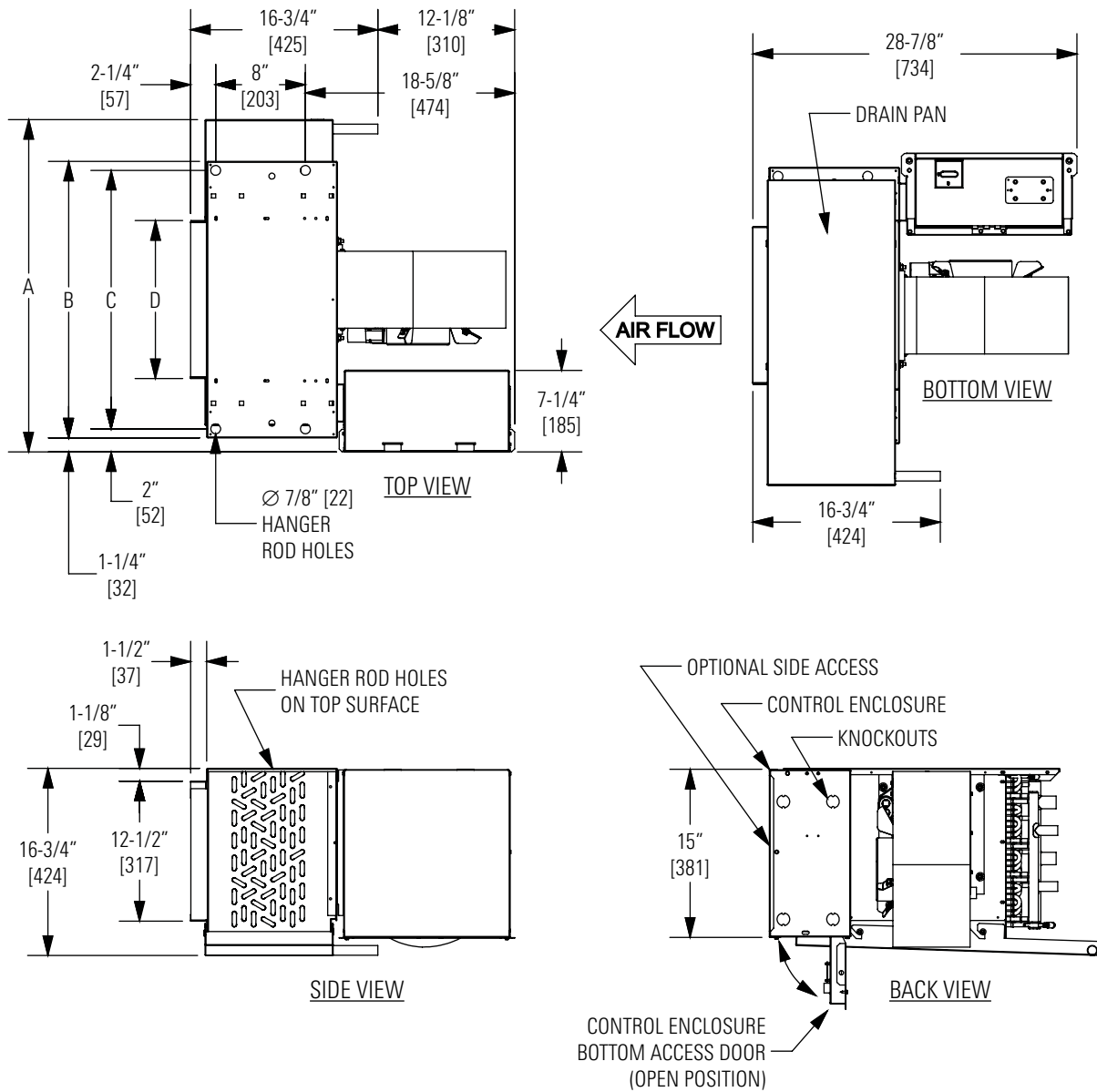

DIMENSIONS				
UNIT SIZE	A	B	C	E
06	34-7/8" [886]	24-5/8" [721]	23-1/8" [587]	14" [356]
08	39-7/8" [1013]	29-5/8" [737]	28-1/8" [714]	19" [483]
10	43-7/8" [1114]	33-5/8" [838]	32-1/8" [816]	23" [584]
12	48-7/8" [1241]	38-5/8" [965]	37-1/8" [943]	28" [711]
14	53-7/8" [1368]	43-5/8" [1092]	42-1/8" [1070]	33" [838]
16	58-7/8" [1495]	48-5/8" [1219]	47-1/8" [1197]	38" [965]
18	63-7/8" [1622]	53-5/8" [1346]	52-1/8" [1324]	43" [1092]
20	67-7/8" [1724]	57-5/8" [1448]	56-1/8" [1426]	47" [1194]

NOTES:

1. All dimensions in Inches [millimeters]. All dimensions ±1/4" [6mm]. Metric values are soft conversion.
2. Right hand unit shown, Left hand unit opposite.
3. Standard control enclosure is mounted on unit side opposite cooling coil connections and includes (4) knockouts on (2) sides. Provide sufficient clearance to access electrical controls and comply with applicable codes and ordinances.

FIELD CONNECTIONS

MODEL THHP / THHC FIELD CONNECTIONS (2-PIPE)

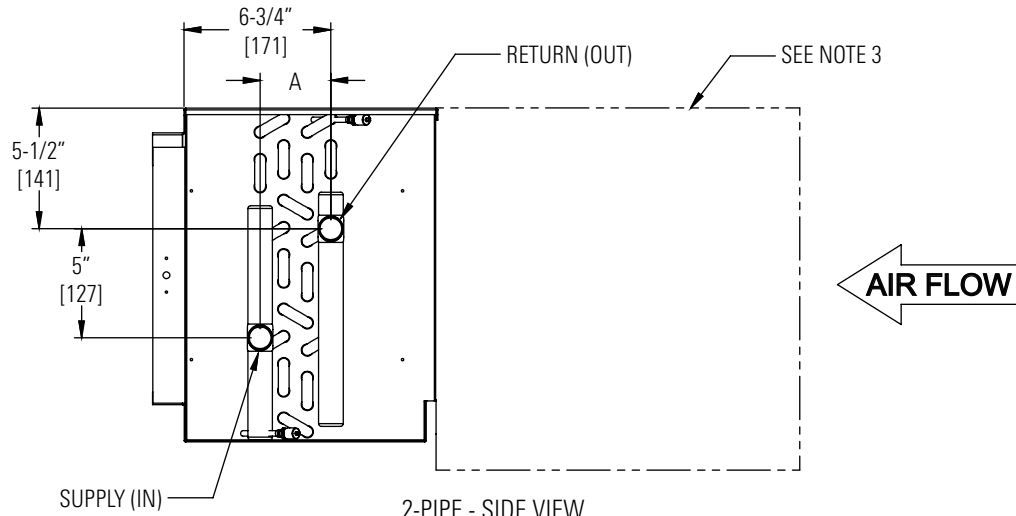

2-PIPE - SIDE VIEW
LH SHOWN RH OPPOSITE

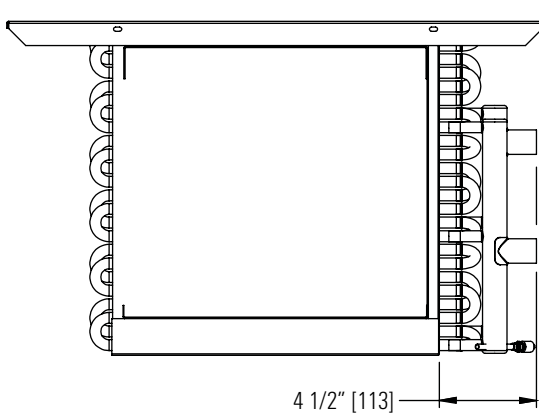

2-PIPE - FRONT VIEW
LH SHOWN RH OPPOSITE

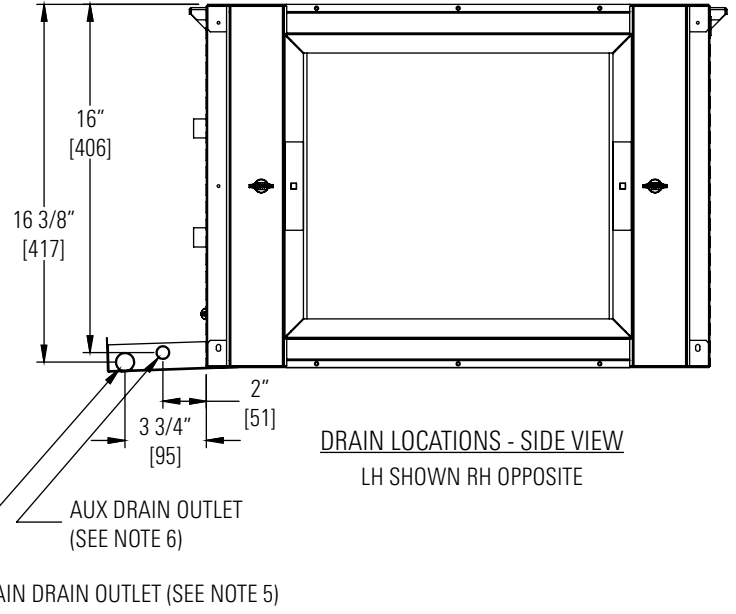

DRAIN LOCATIONS - SIDE VIEW
LH SHOWN RH OPPOSITE

UNIT SIZE	COIL ROWS	A (1/2" Ø COIL)	A (3/8" Ø COIL)
2 PIPE HEATING	1	1-1/8" [29]	7/8" [22]
	2	1-1/8" [29]	7/8" [22]
	3	2-1/8" [54]	1-3/4" [44]
	4	3-1/4" [83]	2-5/8" [67]
2 PIPE COOLING	3	2-1/8" [54]	1-3/4" [44]
	4	3-1/4" [83]	2-5/8" [67]
	6	5-3/8" [137]	4-3/8" [86]

NOTES:

- All dimensions in Inches [millimeters]. All dimensions ±1/2" [13mm]. Metric values are soft conversion.
- All drawings subject to change without notice.
- Model "THHP" unit shown, typical for model "THHC" units. Connections shown are internal on "THHE" units.
- Connection Size: See Connection Size submittal.
- Standard externally foam coated galvanize steel drain pan has 7/8" ODM copper outlet. Stainless steel drain pan has 3/4" MPT galvanize steel outlet.
- Aux. drain outlet is 5/8" ODM copper or 3/8" MPT galvanized steel respectively.
- Single Row/Single Circuit headers are vertical (Horizontal Distance is 0").

FIELD CONNECTIONS

MODEL THHP / THHC FIELD CONNECTIONS (4 PIPE REHEAT)

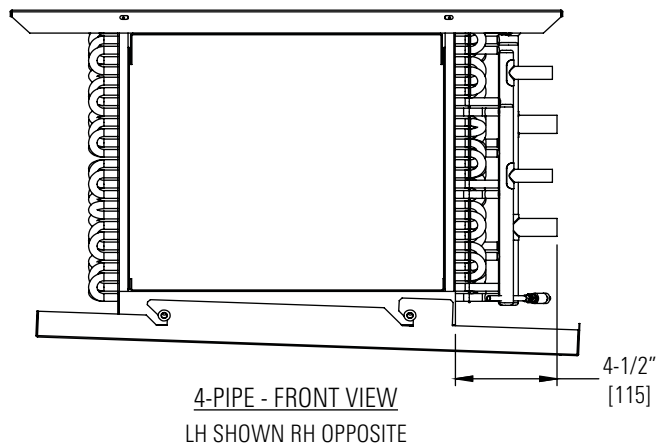
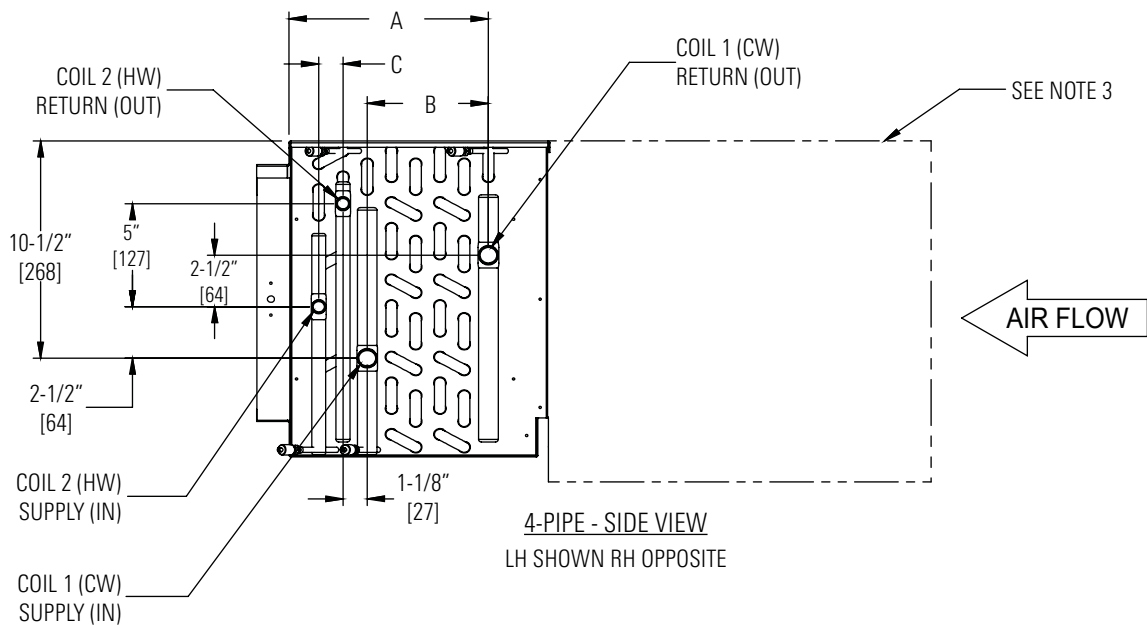

UNIT TYPE: 4 PIPE RE-HEAT				
COIL 1 CW ROWS	COIL 2 HW ROWS	1/2" COIL Ø		
		A	B	C
3	1	6-3/4" [171]	1-5/8" [143]	1-1/4" [32]
3	2	6-3/4" [171]	1-7/8" [48]	1-1/8" [29]
3	3	6-3/4" [171]	2" [51]	2-1/4" [57]
4	1	6-3/4" [171]	3" [76]	1-1/4" [32]
4	2	6-3/4" [171]	3" [76]	1-1/8" [29]
3	4	8-7/8" [225]	2" [51]	3-1/4" [83]
4	3	8-7/8" [225]	3-1/4" [83]	2" [51]
4	4	8-7/8" [225]	3-1/4" [83]	3-1/4" [83]
6	1	8-7/8" [225]	5" [127]	1-1/8" [29]
6	2	8-7/8" [225]	5-1/4" [133]	1-1/8" [29]

NOTES:

1. All dimensions in Inches [millimeters]. All dimensions $\pm 1/2"$ [13mm]. Metric values are soft conversion.
2. All drawings subject to change without notice.
3. Model "THHP" unit shown, typical for model "THHC" units. Connections shown are internal on "THHE" units.
4. Connection Size: See Connection Size submittal.
5. Standard externally foam coated galvanize steel drain pan has 7/8" ODM copper outlet. Stainless steel drain pan has 3/4" MPT galvanize steel outlet.
6. Aux. drain outlet is 5/8" ODM copper or 3/8" MPT galvanized steel respectively.
7. Single Row/Single Circuit headers are vertical (Horizontal Distance is 0").

FIELD CONNECTIONS

MODEL THHP / THHC FIELD CONNECTIONS (CONT'D)

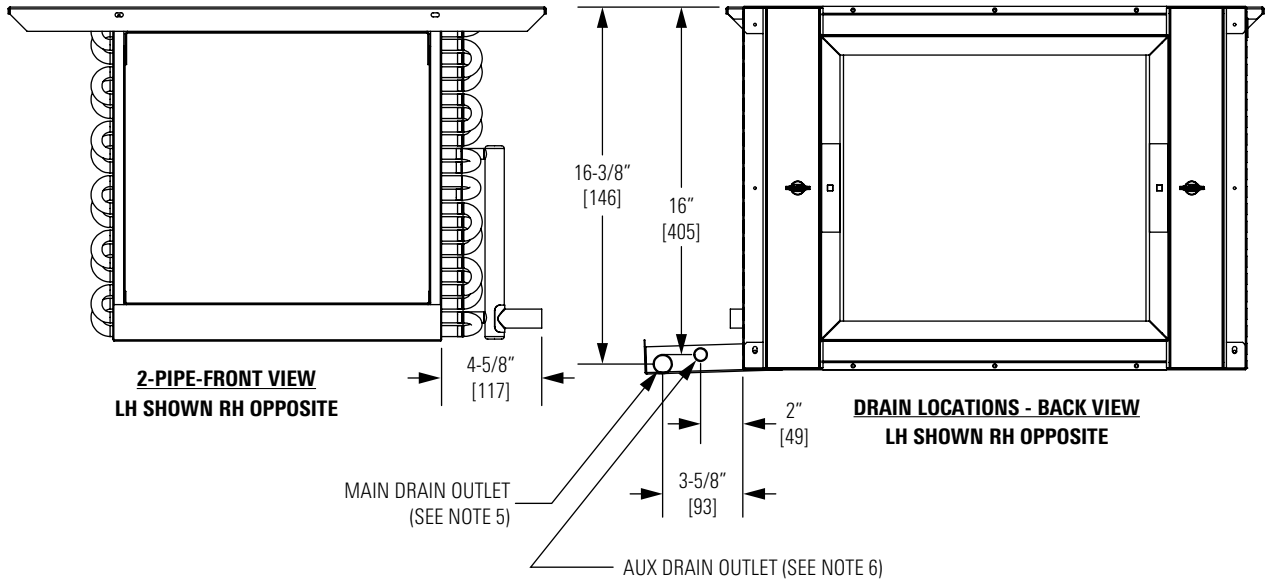
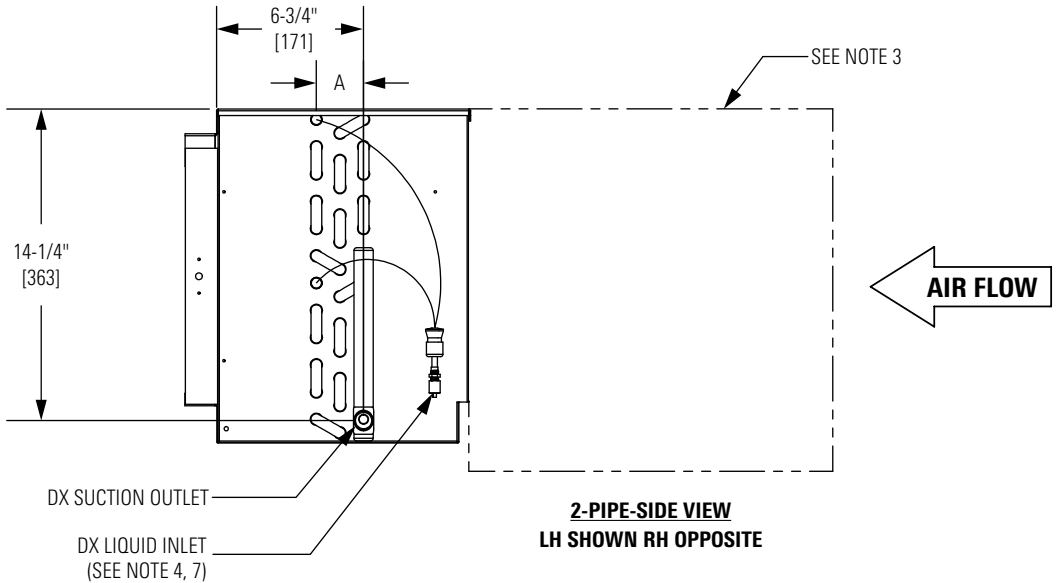

UNIT TYPE	DX COIL ROWS	A (1/2" Ø COIL)
2 Pipe Cooling	3	2-1/8" [55]
	4	3-1/4" [82]
	6	5-3/8" [137]

NOTES:

1. All dimensions are inches [millimeters] All dimensions 1/2 [13mm]. Metric values are soft conversion.
2. All drawings subject to change without notice.
3. Model "HPP" unit shown, typical for model "HPF" units. Connections shown are internal on "HPE" units.
4. Connection Size: See 82-80053 Coil Connections.
5. Standard externally foam coated galvanize steel drain pan has 7/8" ODM copper outlet. Stainless steel drain pan has 3/4" MPT galvanize steel outlet.
6. Aux. drain outlet is 5/8" ODM copper or 3/8" MPT galvanized steel respectively.
7. Liquid Inlet arrangement may vary

FIELD CONNECTIONS

MODEL THHP / THHC FIELD CONNECTIONS (CONT'D)

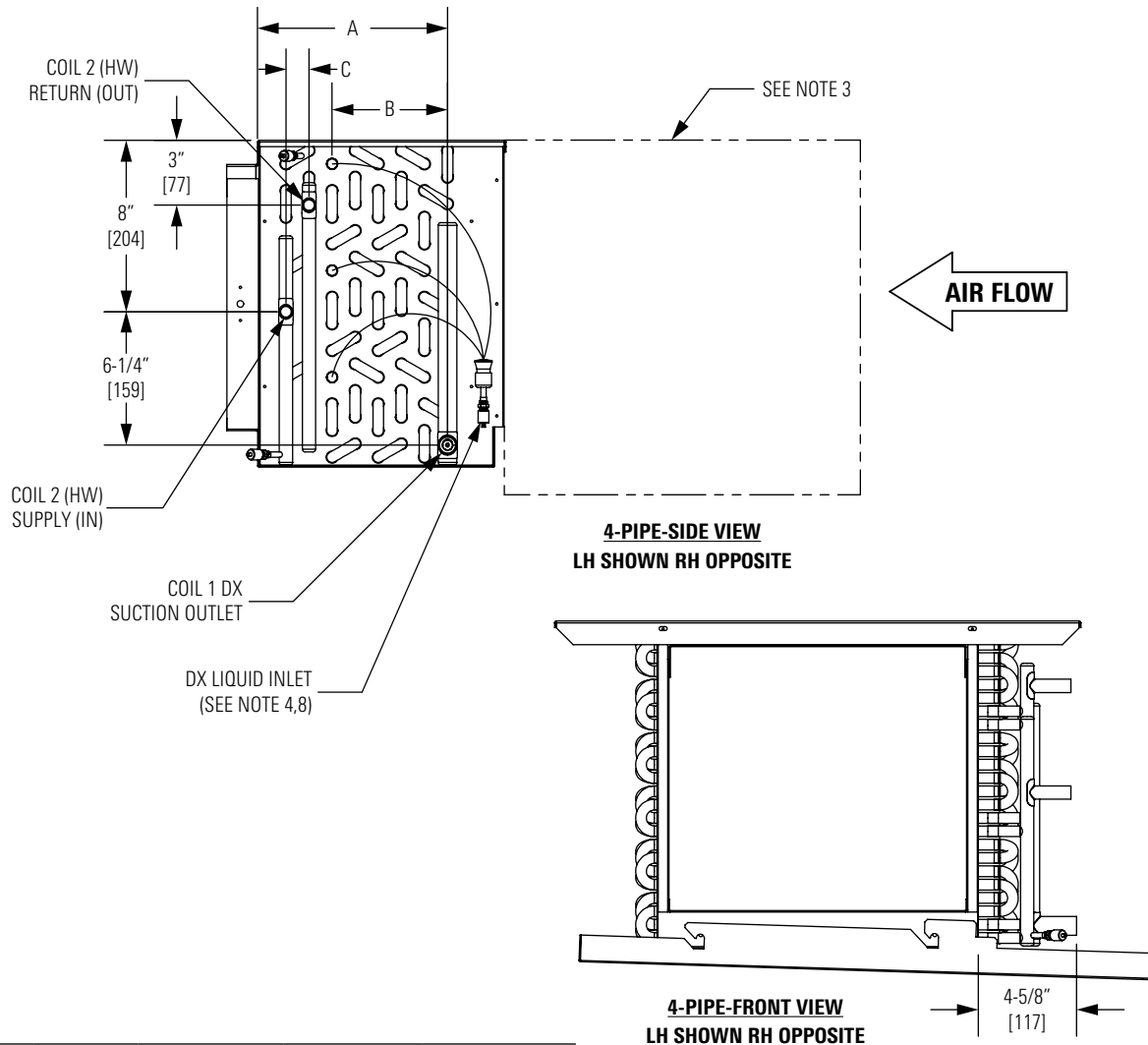

UNIT TYPE: 4 PIPE RE-HEAT				
COIL 1 DX ROWS	COIL 2 HW ROWS	1/2" COIL Ø		
		A	B	C
3	1	6-3/4" [171]	2-1/8" [52]	7/8" [22] 7
3	2	6-3/4" [171]	2-1/8" [52]	1-1/8" [29]
3	3	6-3/4" [171]	2-1/8" [52]	2-1/8" [54]
4	1	6-3/4" [171]	3-1/4" [83]	1" [25.5] 7
4	2	6-3/4" [171]	3-1/4" [83]	1" [25.5]
3	4	8-7/8" [225]	2-1/8" [52]	3-1/4" [83]
4	3	8-7/8" [225]	3-1/4" [83]	2-1/4" [54]
4	4	8-7/8" [225]	3-1/4" [83]	3-1/4" [83]
6	1	8-7/8" [225]	5-1/2" [140]	7/8" [22]
6	2	8-7/8" [225]	5-1/2" [140]	1-1/8" [27]

NOTES:

1. All dimensions are inches [millimeters]. All dimensions 1/2 [13mm]. Metric values are soft conversion.
2. All drawings subject to change without notice.
3. Model "HPP" unit shown, typical for model "HPF" units. Connections shown are internal on "HPE" units.
4. Connection Size: See 82-80053 Coil Connections.
5. Standard externally foam coated galvanize steel drain pan has 7/8" ODM copper outlet. Stainless steel drain pan has 3/4" MPT galvanize steel outlet.
6. Aux. drain outlet is 5/8" ODM copper or 3/8" MPT galvanized steel respectively.
7. 7 Single Row/Single Circuit headers are vertical (Horizontal Distance is 0")
8. Liquid Inlet arrangement may vary

FIELD CONNECTIONS

MODEL THHP / THHC FIELD CONNECTIONS (CONT'D)

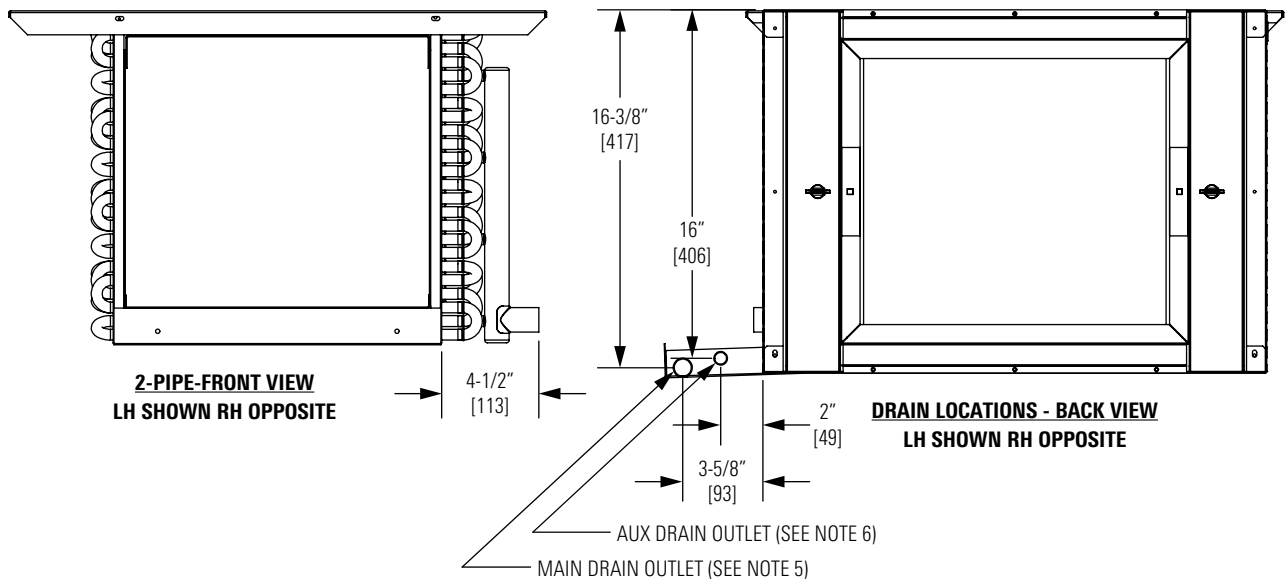
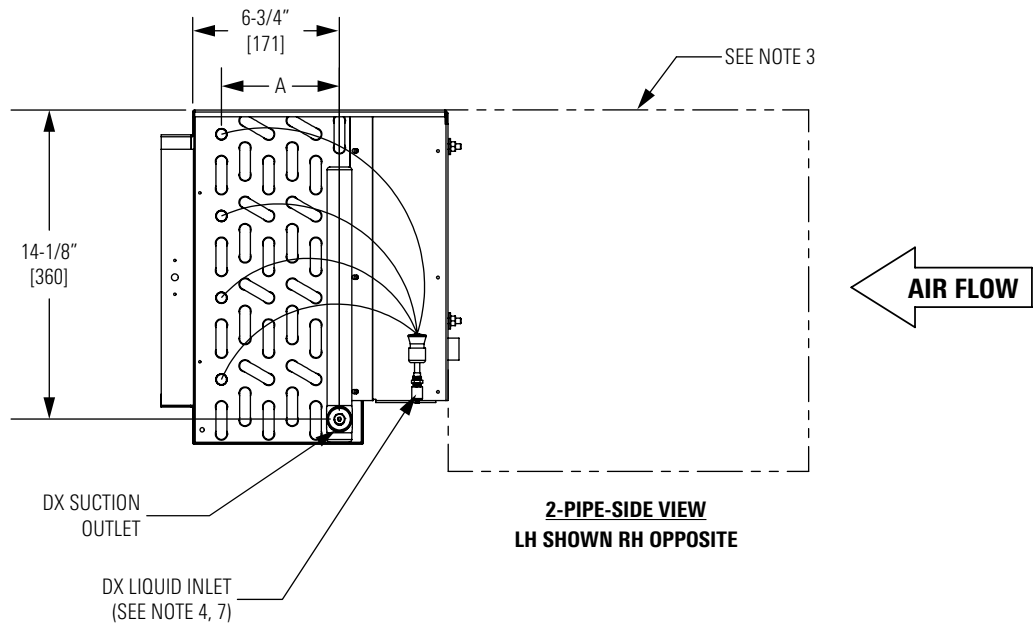

UNIT TYPE	DX COIL ROWS	A (1/2" Ø COIL)
2 Pipe Cooling	3	2-1/8" [55]
	4	3-1/4" [82]
	6	5-3/8" [137]



NOTES:

1. All dimensions are inches [millimeters]. All dimensions 1/2 [13mm]. Metric values are soft conversion.
2. All drawings subject to change without notice.
3. Model "HPP" unit shown, typical for model "HPF" units. Connections shown are internal on "HPE" units.
4. Connection Size: See 82-80053 Coil Connections.
5. Standard externally foam coated galvanize steel drain pan has 7/8" ODM copper outlet. Stainless steel drain pan has 3/4" MPT galvanize steel outlet.
6. Aux. drain outlet is 5/8" ODM copper or 3/8" MPT galvanized steel respectively.
7. Liquid Inlet arrangement may vary

FIELD CONNECTIONS

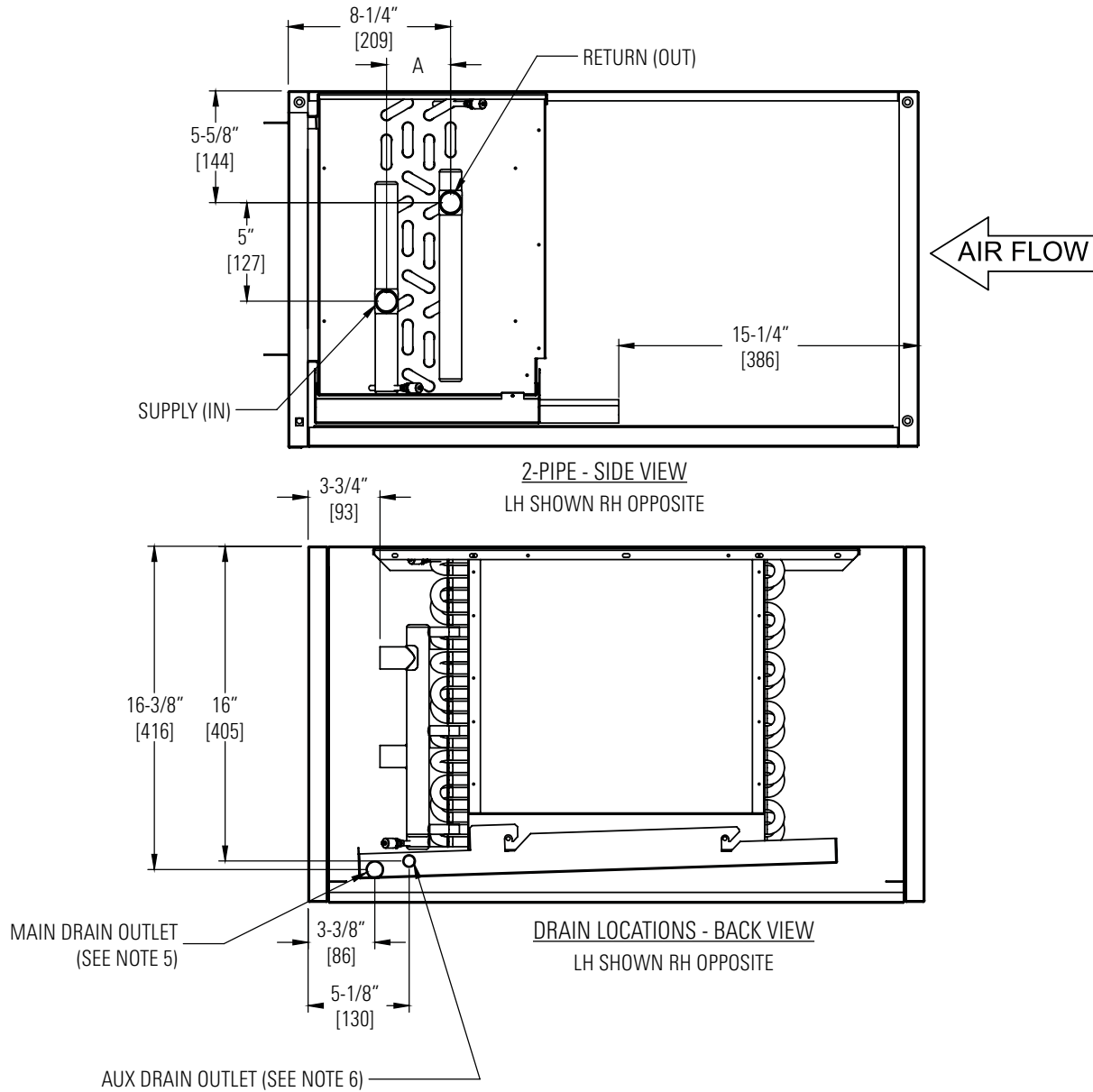
MODEL THHE FIELD CONNECTIONS (2-PIPE)



UNIT SIZE	COIL ROWS	A (1/2" Ø COIL)	A (3/8" Ø COIL)
2 PIPE HEATING	1	1-1/8" [29] 	7/8" [22] 
	2	1-1/8" [29]	7/8" [22]
	3	2-1/8" [54]	1-3/4" [44]
	4	3-1/4" [83]	2-5/8" [67]
2 PIPE COOLING	3	2-1/8" [54]	1-3/4" [44]
	4	3-1/4" [83]	2-5/8" [67]
	6	5-3/8" [137]	4-3/8" [86]

NOTES:

1. All dimensions in Inches [millimeters]. All dimensions $\pm 1/2"$ [13mm]. Metric values are soft conversion.
2. All drawings subject to change without notice.
3. Model "THHE" unit shown, Side panel hidden for clarity.
4. Connection Size: See Connection Size submittal.
5. Standard externally foam coated galvanize steel drain pan has 7/8" ODM copper outlet. Stainless steel drain pan has 3/4" MPT galvanize steel outlet.
6. Aux. drain outlet is 5/8" ODM copper or 3/8" MPT galvanized steel respectively.
7. Single Row/Single Circuit headers are vertical (Horizontal Distance is 0").

FIELD CONNECTIONS

MODEL THHE FIELD CONNECTIONS (4 PIPE REHEAT, 1/2" COIL)

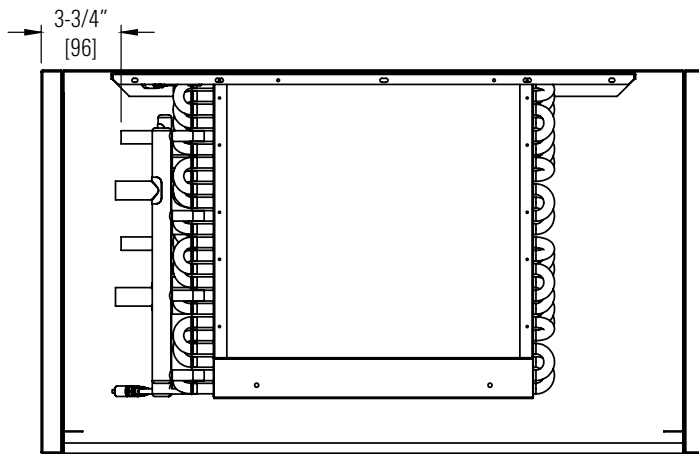
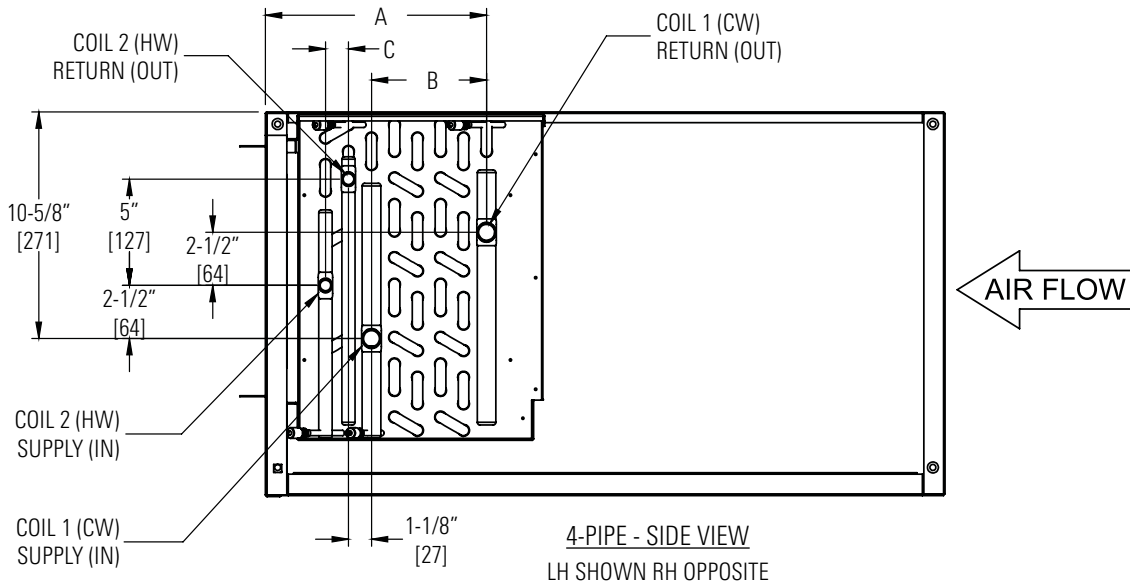

UNIT TYPE: 4 PIPE RE-HEAT				
COIL 1 CW ROWS	COIL 2 HW ROWS	1/2" COIL Ø		
		A	B	C
3	1	8-1/4" [210]	1-5/8" [143]	1-1/4" [32]
3	2	8-1/4" [210]	1-7/8" [48]	1-1/8" [29]
3	3	8-1/4" [210]	2" [51]	2-1/4" [57]
4	1	8-1/4" [210]	3" [76]	1-1/4" [32]
4	2	8-1/4" [210]	3" [76]	1-1/8" [29]
3	4	10-3/8" [264]	2" [51]	3-1/4" [83]
4	3	10-3/8" [264]	3-1/4" [83]	2" [51]
4	4	10-3/8" [264]	3-1/4" [83]	3-1/4" [83]
6	1	10-3/8" [264]	5" [127]	1-1/8" [29]
6	2	10-3/8" [264]	5-1/4" [133]	1-1/8" [29]

NOTES:

1. All dimensions in Inches [millimeters]. All dimensions $\pm 1/2"$ [13mm]. Metric values are soft conversion.
2. All drawings subject to change without notice.
3. Model "THHE" unit shown, Side panel and drain pan hidden for clarity.
4. Connection Size: See Connection Size submittal.
5. Standard externally foam coated galvanize steel drain pan has 7/8" ODM copper outlet. Stainless steel drain pan has 3/4" MPT galvanize steel outlet.
6. Aux. drain outlet is 5/8" ODM copper or 3/8" MPT galvanized steel respectively.
7. Single Row/Single Circuit headers are vertical (Horizontal Distance is 0").

FIELD CONNECTIONS

MODEL THHE FIELD CONNECTIONS (4 PIPE REHEAT, 3/8" COIL)

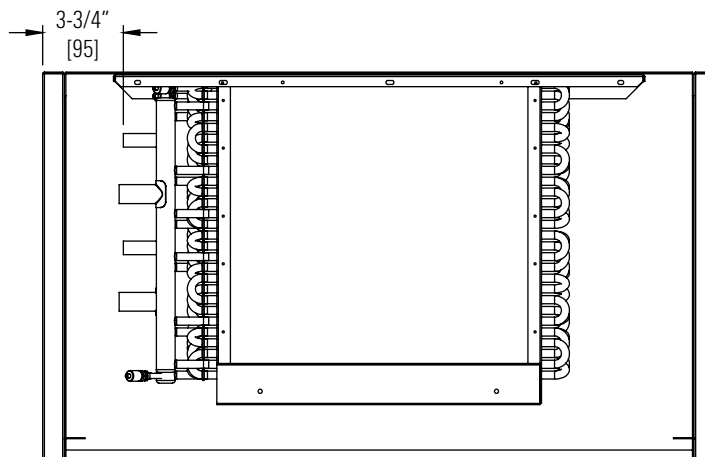
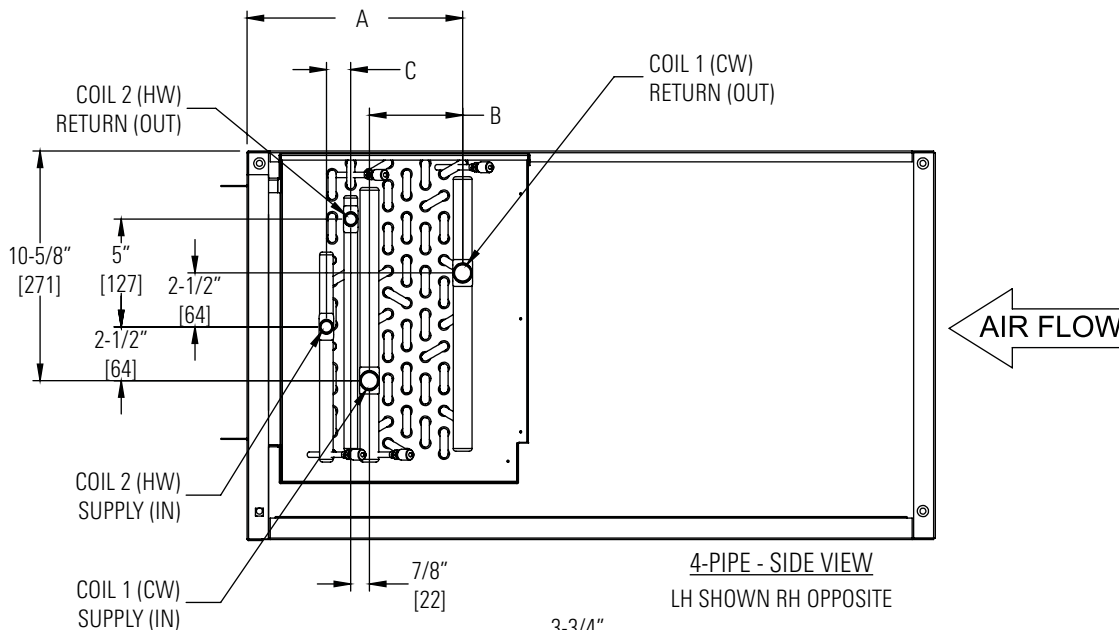

UNIT TYPE: 4 PIPE RE-HEAT				
COIL 1 CW ROWS	COIL 2 HW ROWS	3/8" COIL Ø		
		A	B	C
3	1	8-1/4" [210]	1-1/2" [38]	1" [25]
3	2	8-1/4" [210]	1-3/8" [35]	1" [25]
3	3	8-1/4" [210]	1-3/4" [44]	1-1/2" [38]
4	1	8-1/4" [210]	1-3/4" [44]	1" [25]
4	2	8-1/4" [210]	2-1/4" [57]	1" [25]
3	4	10" [254]	1-1/2" [38]	2-5/8" [67]
4	3	10" [254]	2-5/8" [67]	1-1/2" [38]
4	4	10" [254]	2-5/8" [67]	2-1/4" [57]
6	1	10" [254]	3-1/2" [89]	1" [25]
6	2	10" [254]	4" [102]	1" [25]



NOTES:

1. All dimensions in Inches [millimeters]. All dimensions ±1/2" [13mm]. Metric values are soft conversion.
2. All drawings subject to change without notice.
3. Model "THHE" unit shown, Side panel and drain pan hidden for clarity.
4. Connection Size: See Connection Size submittal.
5. Standard externally foam coated galvanize steel drain pan has 7/8" ODM copper outlet. Stainless steel drain pan has 3/4" MPT galvanize steel outlet.
6. Aux. drain outlet is 5/8" ODM copper or 3/8" MPT galvanized steel respectively.
7. Single Row/Single Circuit headers are vertical (Horizontal Distance is 0").

FIELD CONNECTIONS

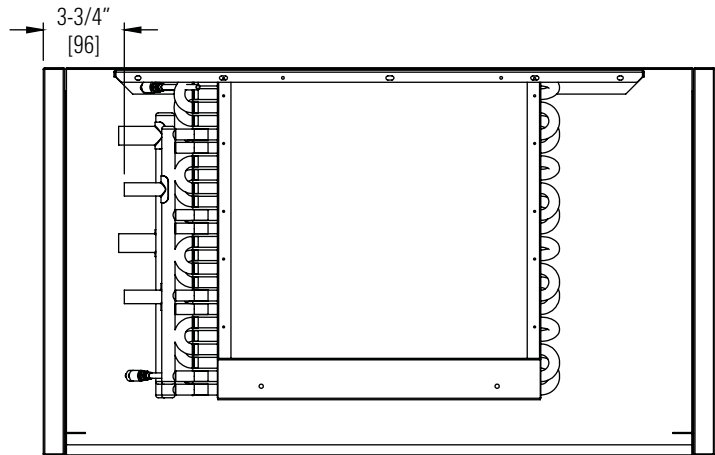
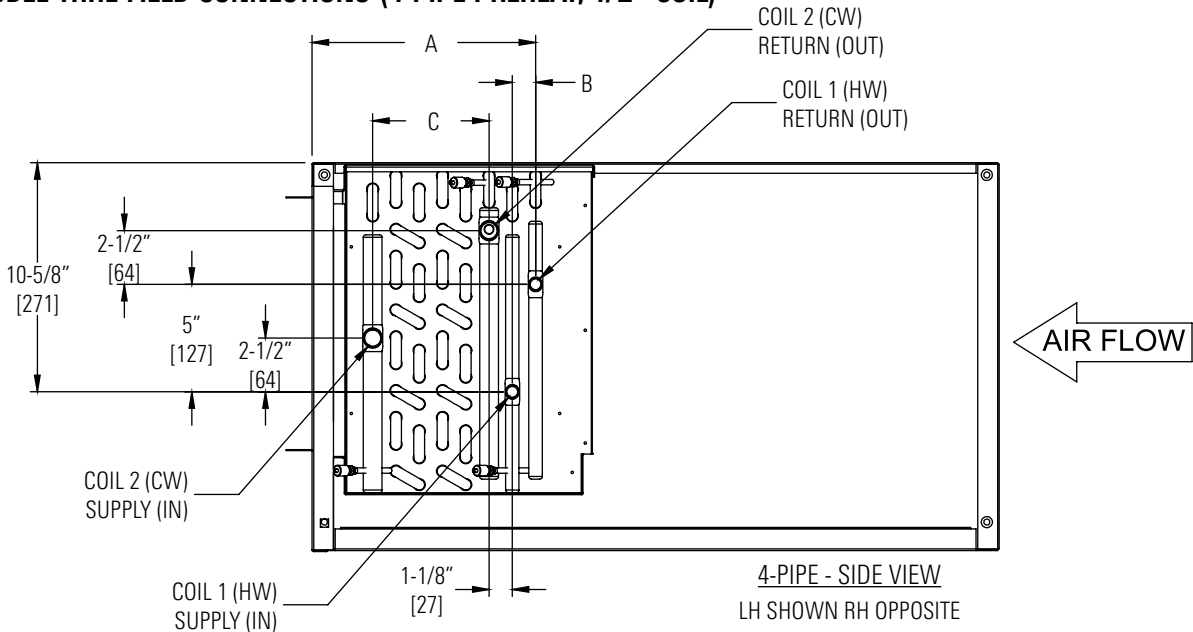
MODEL THHE FIELD CONNECTIONS (4 PIPE PREHEAT, 1/2" COIL)



UNIT TYPE: 4 PIPE PRE-HEAT				
COIL 1 HW ROWS	COIL 2 CW ROWS	1/2" COIL Ø		
		A	B	C
1	3	9-1/8" [232]	1-1/8" [29] 	1-5/8" [41]
1	4	9-1/8" [232]	1-1/8" [29] 	2-1/2" [64]
2	3	8-1/4" [210]	1-1/8" [29]	2-1/8" [54]
2	4	8-1/4" [210]	1-1/8" [29]	3-1/8" [79]
3	3	8-1/4" [210]	2-1/8" [76]	2" [51]
1	6	11-1/8" [283]	1-1/8" [29] 	4-3/4" [121]
2	6	10-3/8" [264]	1-1/8" [29]	5-1/4" [133]
3	4	10-3/8" [264]	2-1/8" [54]	3-1/8" [79]
4	3	10-3/8" [264]	3-1/4" [83]	2-1/8" [54]
4	4	10-3/8" [264]	3-1/4" [83]	3-1/8" [79]

4-PIPE - BACK VIEW
LH SHOWN RH OPPOSITE



NOTES:

1. All dimensions in Inches [millimeters]. All dimensions $\pm 1/2"$ [13mm]. Metric values are soft conversion.
2. All drawings subject to change without notice.
3. Model "THHE" unit shown, Side panel and drain pan hidden for clarity.
4. Connection Size: See Connection Size submittal.
5. Standard externally foam coated galvanize steel drain pan has 7/8" ODM copper outlet. Stainless steel drain pan has 3/4" MPT galvanize steel outlet.
6. Aux. drain outlet is 5/8" ODM copper or 3/8" MPT galvanized steel respectively.
7. Single Row/Single Circuit headers are vertical (Horizontal Distance is 0").

FIELD CONNECTIONS

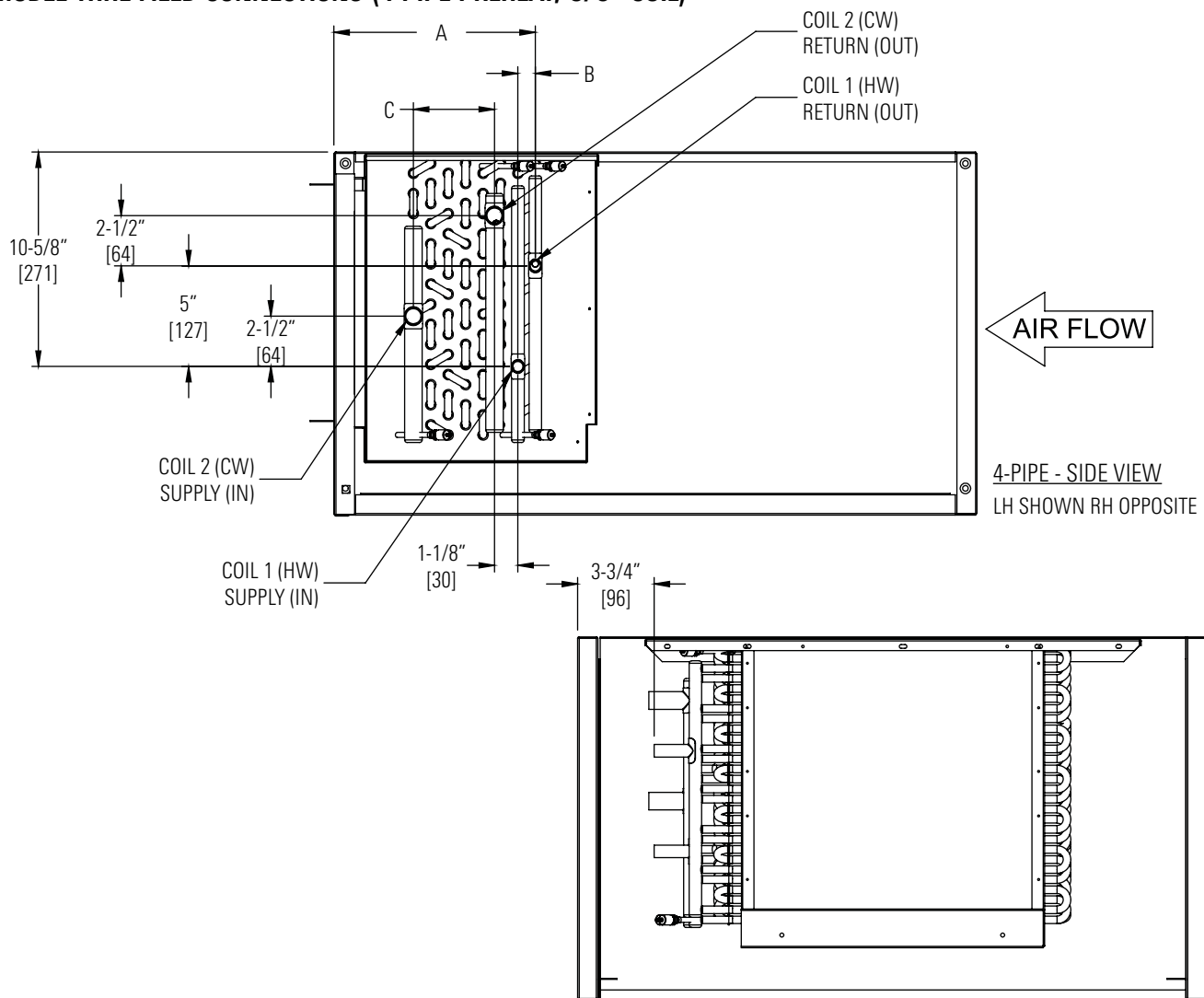
MODEL THHE FIELD CONNECTIONS (4 PIPE PREHEAT, 3/8" COIL)



UNIT TYPE: 4 PIPE PRE-HEAT				
COIL 1 HW ROWS	COIL 2 CW ROWS	3/8" COIL Ø		
		A	B	C
1	3	9" [229]	1" [25] 	1-1/2" [38]
1	4	9" [229]	1" [25] 	1-3/4" [44]
2	3	8-1/4" [210]	1" [25]	1-1/2" [38]
2	4	8-1/4" [210]	1" [25]	2" [51]
3	3	8-1/4" [210]	1-3/4" [44]	1-1/2" [38]
1	6	10-3/4" [273]	1" [25] 	3-1/2" [89]
2	6	10" [254]	1" [25]	3-3/4" [95]
3	4	10" [254]	1-3/4" [44]	2-1/4" [57]
4	3	10" [254]	2-5/8" [67]	1-1/2" [38]
4	4	10" [254]	2-5/8" [67]	2-1/4" [57]

NOTES:

1. All dimensions in Inches [millimeters]. All dimensions $\pm 1/2"$ [13mm]. Metric values are soft conversion.
2. All drawings subject to change without notice.
3. Model "THHE" unit shown, Side panel and drain pan hidden for clarity.
4. Connection Size: See Connection Size submittal.
5. Standard externally foam coated galvanize steel drain pan has 7/8" ODM copper outlet. Stainless steel drain pan has 3/4" MPT galvanize steel outlet.
6. Aux. drain outlet is 5/8" ODM copper or 3/8" MPT galvanized steel respectively.
7. Single Row/Single Circuit headers are vertical (Horizontal Distance is 0").

FIELD CONNECTIONS

MODEL THHE FIELD CONNECTIONS (CONT'D)

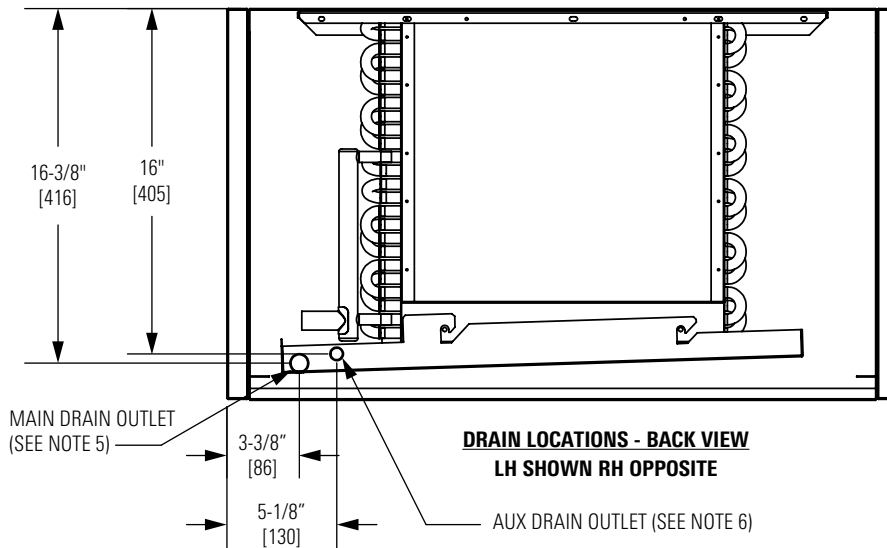
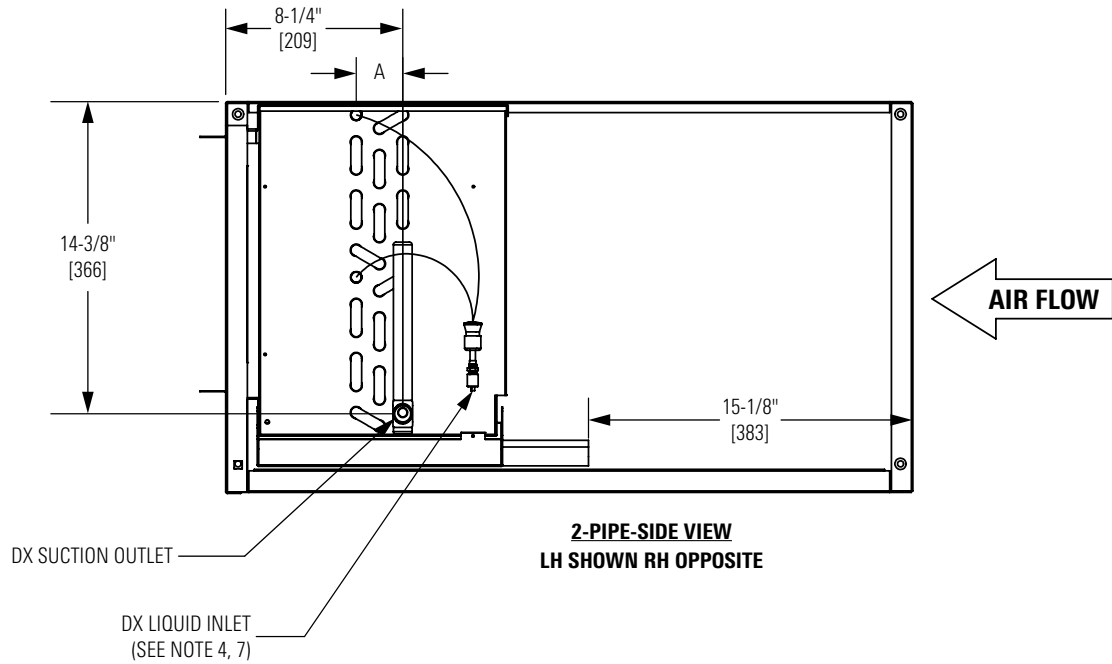

UNIT TYPE	DX COIL ROWS	A (1/2" Ø COIL)
2 Pipe Cooling	3	2-1/8" [55]
	4	3-1/4" [82]
	6	5-3/8" [137]

NOTES:

1. All dimensions are inches [millimeters]. All dimensions 1/2 [13mm]. Metric values are soft conversion.
2. All drawings subject to change without notice.
3. Model "HPE" unit shown. Side panel hidden for clarity.
4. Connection Size: See 82-80053 Coil Connections. Stainless steel drain pan has 3/4" MPT galvanize steel outlet.
5. Standard externally foam coated galvanize steel drain pan has 7/8" ODM copper outlet. Stainless steel drain pan has 3/4" MPT galvanize steel outlet.
6. Aux. drain outlet is 5/8" ODM copper or 3/8" MPT galvanized steel respectively.
7. Liquid Inlet arrangement may vary

FIELD CONNECTIONS

MODEL THH THE FIELD CONNECTIONS (CONT'D)

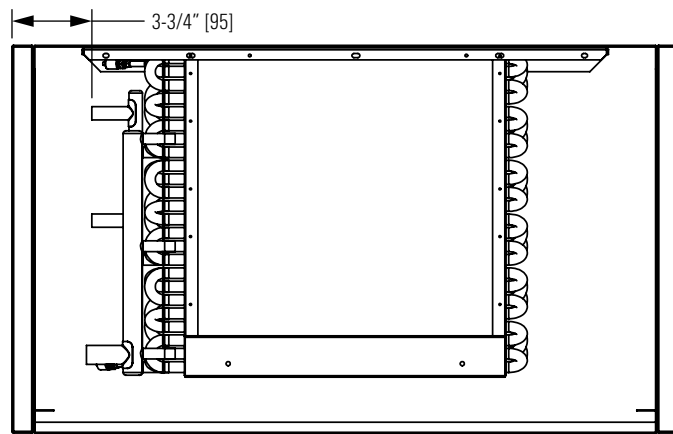
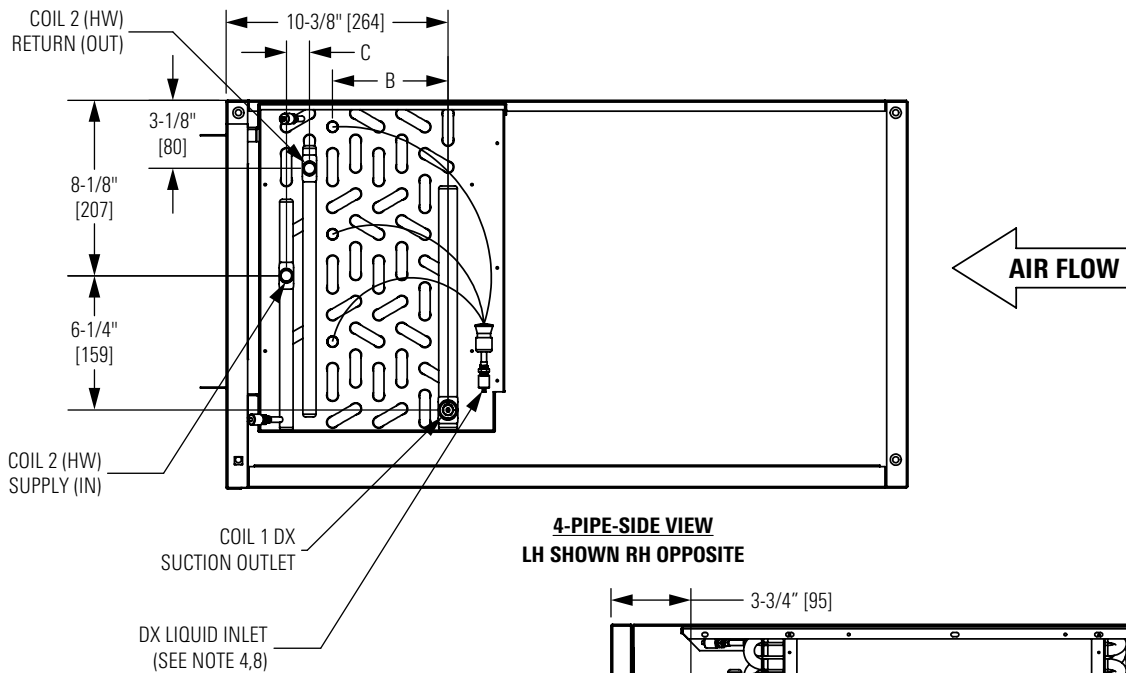

UNIT TYPE: 4 PIPE RE-HEAT				
COIL 1 DX ROWS	COIL 2 HW ROWS	1/2" COIL Ø		
		A	B	C
3	1	8-1/4" [210]	2-1/8" [52]	7/8" [22]
3	2	8-1/4" [210]	2-1/8" [52]	1-1/8" [29]
3	3	8-1/4" [210]	2-1/8" [52]	2-1/8" [54]
4	1	8-1/4" [210]	3-1/4" [83]	1" [25.5]
4	2	8-1/4" [210]	3-1/4" [83]	1" [25.5]
3	4	10-3/8" [364]	2-1/8" [52]	3-1/4" [83]
4	3	10-3/8" [364]	3-1/4" [83]	2-1/4" [54]
4	4	10-3/8" [364]	3-1/4" [83]	3-1/4" [83]
6	1	10-3/8" [364]	5-1/2" [140]	7/8" [22]
6	2	10-3/8" [364]	5-1/2" [140]	1-1/8" [27]

NOTES:

1. All dimensions are inches [millimeters]. All dimensions 1/2 [13mm]. Metric values are soft conversion.
2. All drawings subject to change without notice.
3. Model "HPE" unit shown. Side panel hidden for clarity.
4. Connection Size: See 82-80053 Coil Connections. Stainless steel drain pan has 3/4" MPT galvanize steel outlet.
5. Standard externally foam coated galvanize steel drain pan has 7/8" ODM copper outlet. Stainless steel drain pan has 3/4" MPT galvanize steel outlet.
6. Aux. drain outlet is 5/8" ODM copper or 3/8" MPT galvanized steel respectively.
7. Single Row/Single Circuit headers are vertical (Horizontal Distance is 0")
8. Liquid Inlet arrangement may vary

FIELD CONNECTIONS

MODEL THHE FIELD CONNECTIONS (CONT'D)

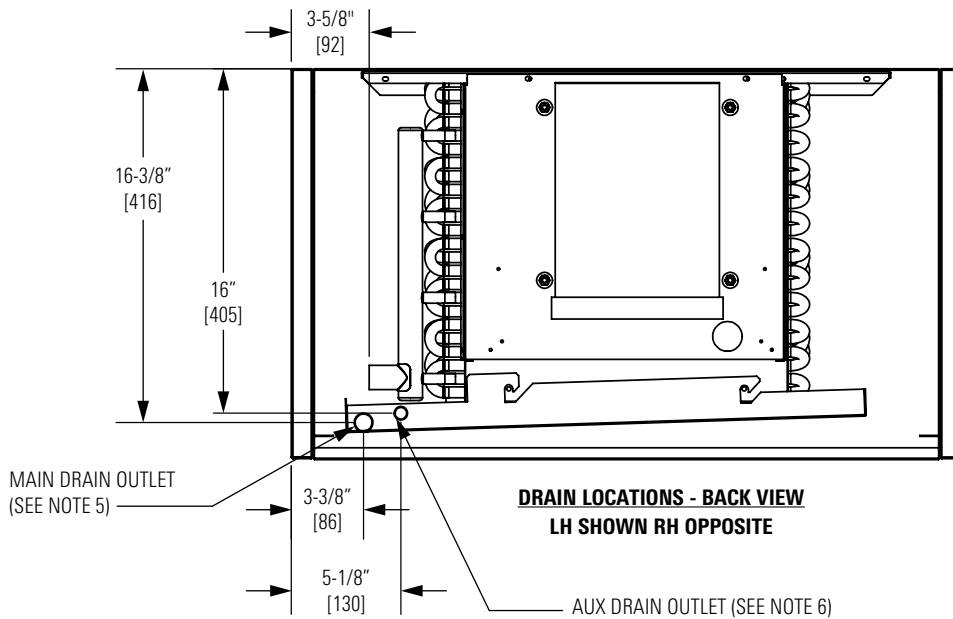
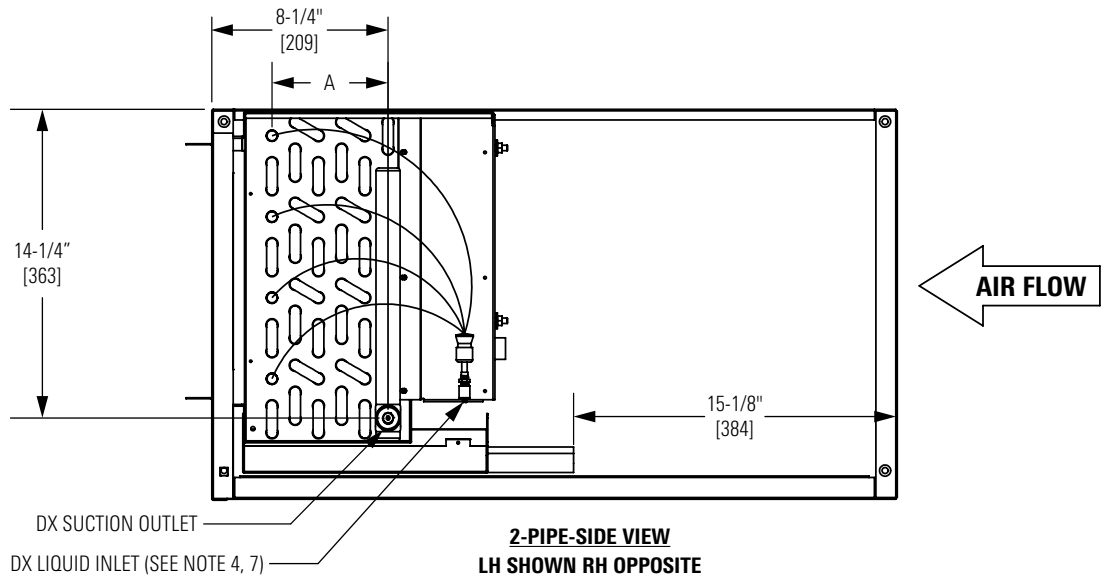

UNIT TYPE	DX COIL ROWS	A (1/2" Ø COIL)
2 Pipe Cooling	3	2-1/8" [55]
	4	3-1/4" [82]
	6	5-3/8" [137]

NOTES:

1. All dimensions are inches [millimeters]. All dimensions 1/2 [13mm]. Metric values are soft conversion.
2. All drawings subject to change without notice.
3. Model "HPE" unit shown. Side panel hidden for clarity.
4. Connection Size: See 82-80053 Coil Connections. Stainless steel drain pan has 3/4" MPT galvanize steel outlet.
5. Standard externally foam coated galvanize steel drain pan has 7/8" ODM copper outlet. Stainless steel drain pan has 3/4" MPT galvanize steel outlet.
6. Aux. drain outlet is 5/8" ODM copper or 3/8" MPT galvanized steel respectively.
7. Liquid Inlet arrangement may vary

VALVE PACKAGE CONNECTIONS

MODEL THHP VALVE PACKAGE CONNECTIONS

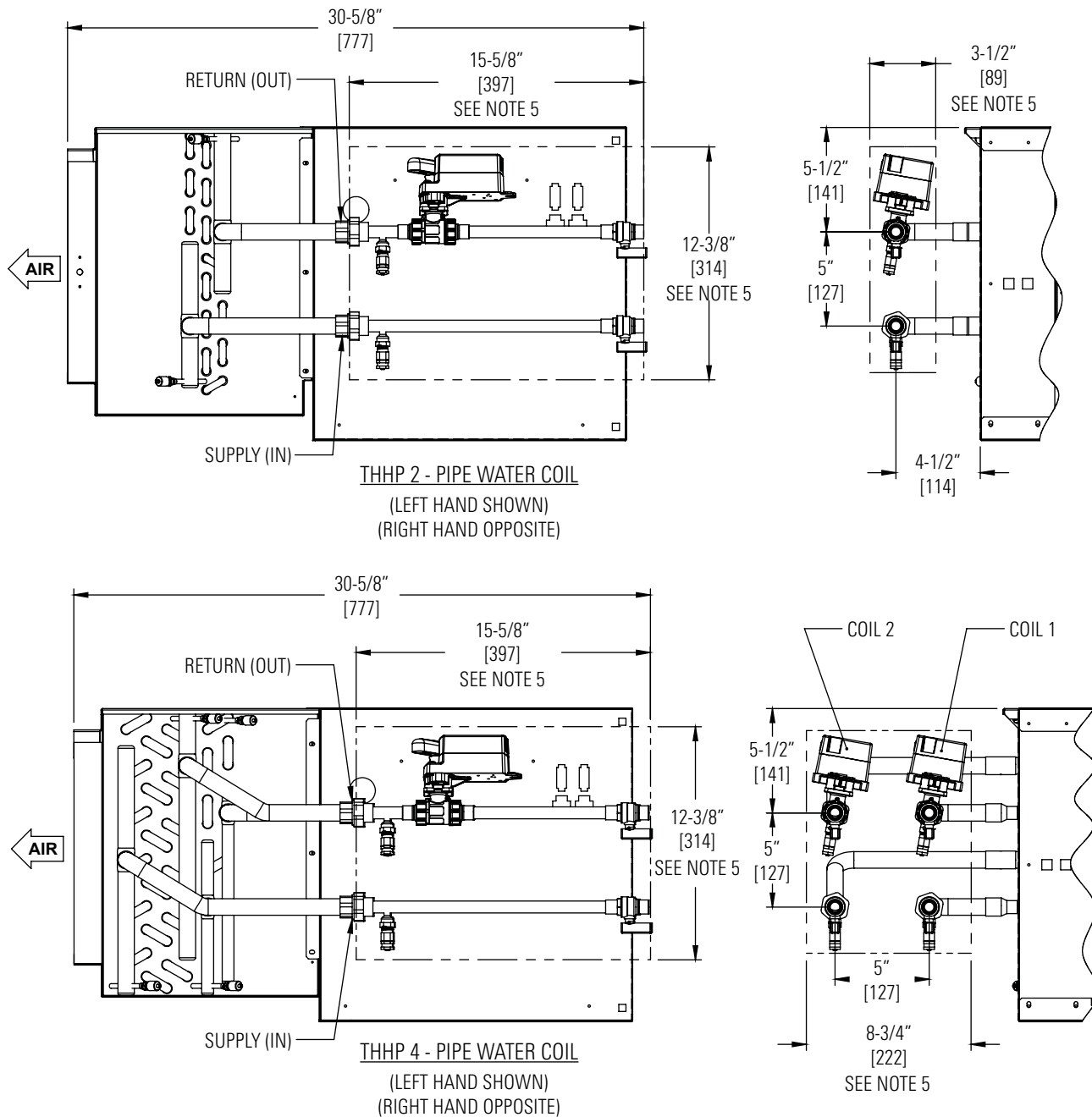

NOTES:

1. All dimensions in Inches [millimeters]. All dimensions $\pm 1/2"$ [13mm]. Metric values are soft conversion.
2. All drawings subject to change without notice.
3. See "Coil Connection Location" drawing for drain pan specifications.
4. Consult software selection summary for valve package components and specifications. Valve package end point dimensions are fixed value, regardless of selected valve package components.
5. Dimensions indicate space requirement for valve package install. Additional service space requirements depend on option selections.

VALVE PACKAGE CONNECTIONS

MODEL THHE STANDARD WIDTH VALVE PACKAGE CONNECTIONS

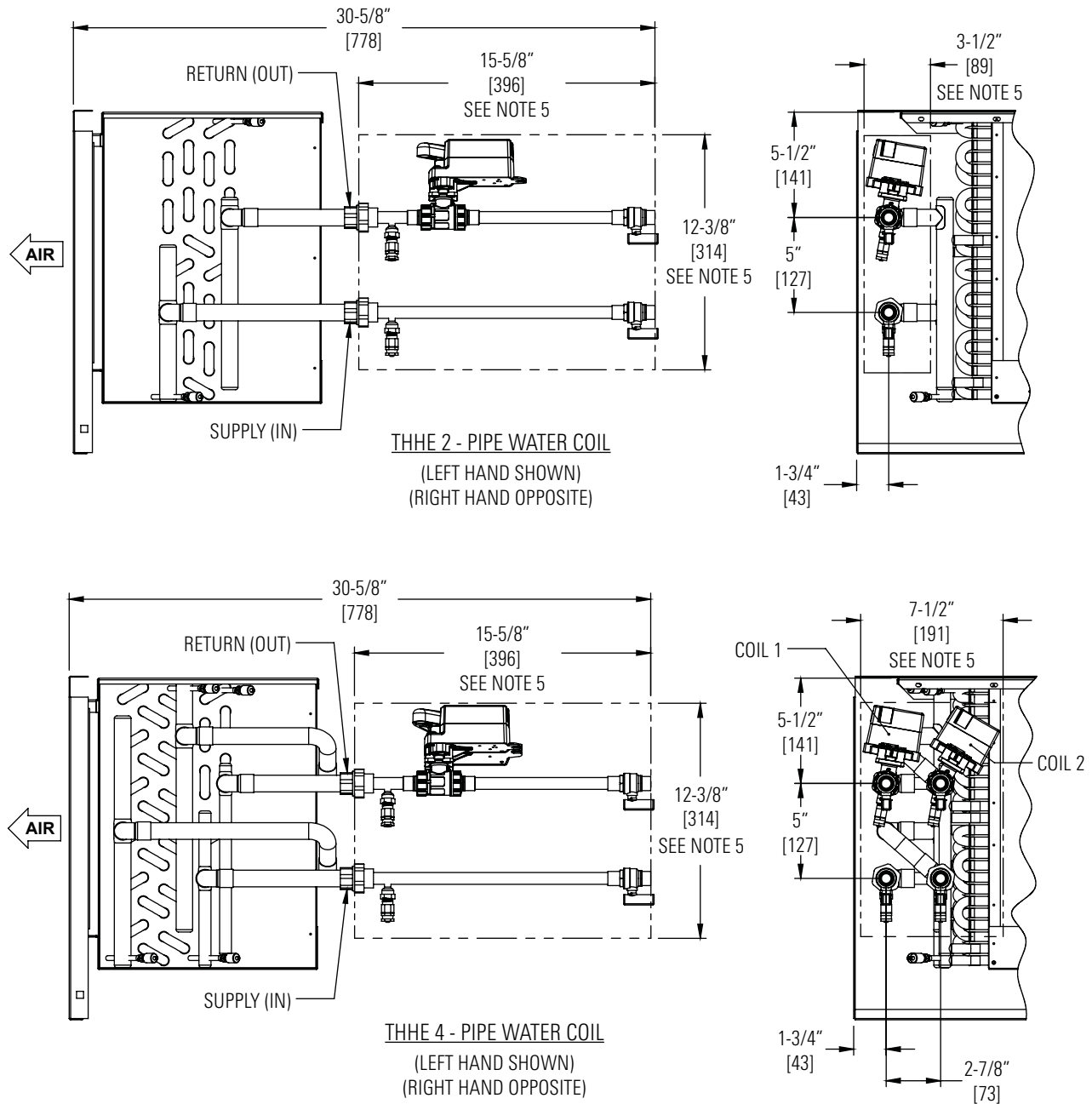

NOTES:

1. All dimensions in Inches [millimeters]. All dimensions $\pm 1/2"$ [13mm]. Metric values are soft conversion.
2. All drawings subject to change without notice.
3. See "Coil Connection Location" drawing for drain pan specifications.
4. Consult software selection summary for valve package components and specifications. Valve package end point dimensions are fixed value, regardless of selected valve package components.
5. Dimensions indicate space requirement for valve package install. Additional service space requirements depend on option selections.

VALVE PACKAGE CONNECTIONS

MODEL THHE EXTENDED WIDTH VALVE PACKAGE CONNECTIONS

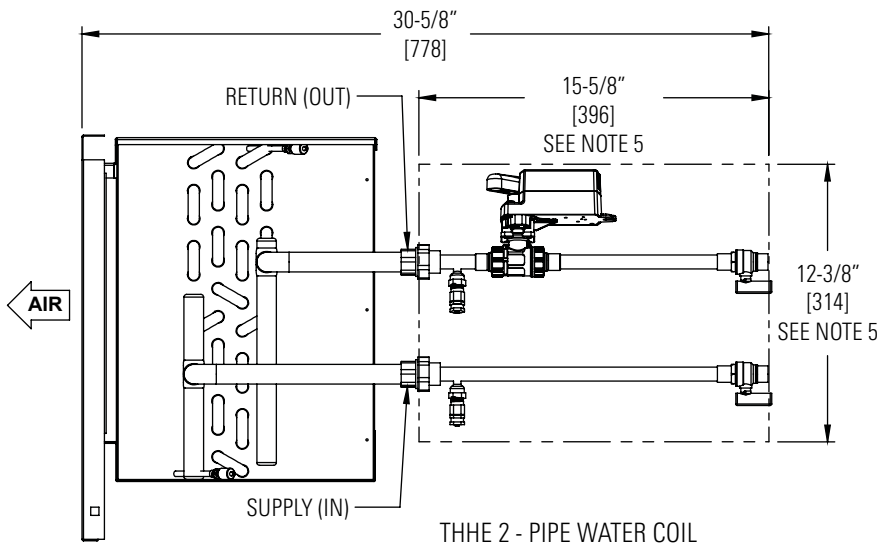

THHE 2 - PIPE WATER COIL
(LEFT HAND SHOWN)
(RIGHT HAND OPPOSITE)

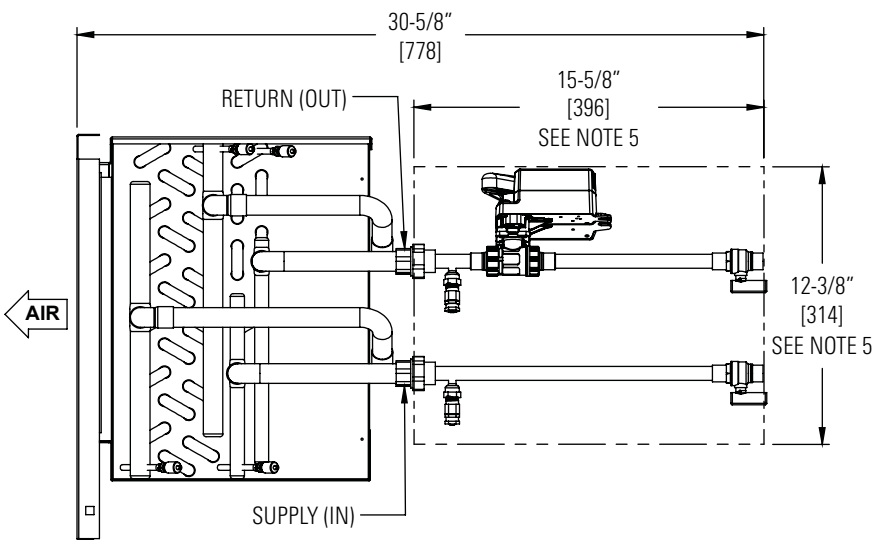
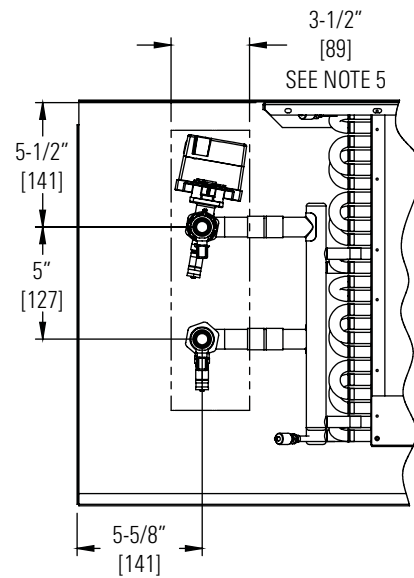

THHE 4 - PIPE WATER COIL
(LEFT HAND SHOWN)
(RIGHT HAND OPPOSITE)

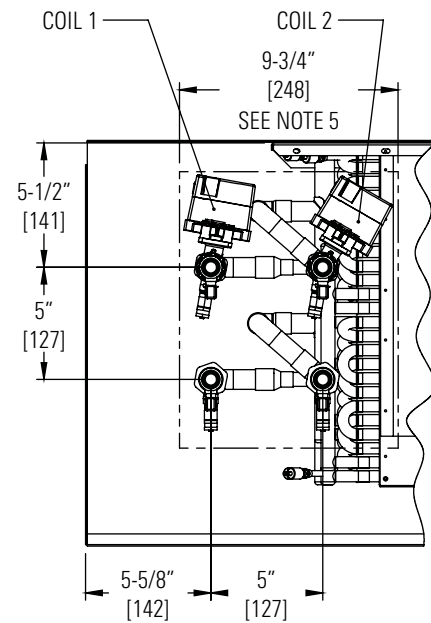

NOTES:

1. All dimensions in Inches [millimeters]. All dimensions $\pm 1/2"$ [13mm]. Metric values are soft conversion.
2. All drawings subject to change without notice.
3. See "Coil Connection Location" drawing for drain pan specifications.
4. Consult software selection summary for valve package components and specifications. Valve package end point dimensions are fixed value, regardless of selected valve package components.
5. Dimensions indicate space requirement for valve package install. Additional service space requirements depend on option selections.

COIL CONNECTIONS

COIL CONNECTIONS - THHP / THHC / THHE

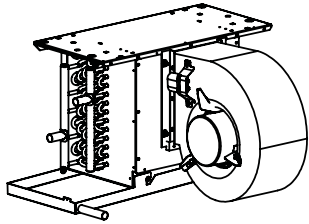

MODEL THHC
HIGH PERFORMANCE FREE RETURN FAN COIL UNIT

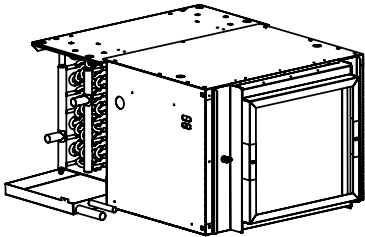

MODEL THHP
HIGH PERFORMANCE PLENUM RETURN FAN COIL UNIT

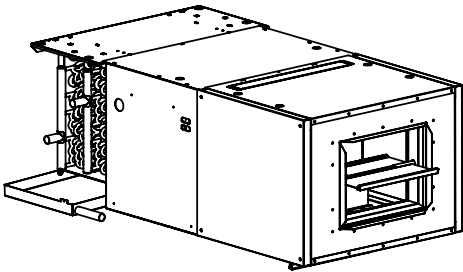

MODEL THHP
HIGH PERFORMANCE PLENUM RETURN FAN COIL UNIT
W/ MIXING BOX

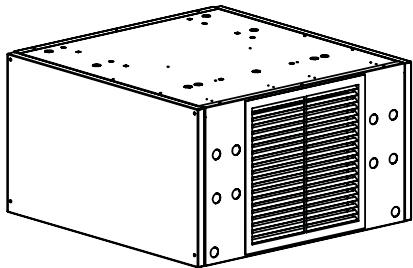

MODEL THHE
HIGH PERFORMANCE EXPOSED CABINET FAN COIL UNIT

NOTES:

1. Table applies to 1/2" and 3/8" tube diameters.
2. Number of circuits does not affect Coil connection size.

WATER & DX COIL CONNECTION SIZES			
UNIT SIZE	TYPE	# ROWS	CONN. SIZE (OD)
06	HW	1	5/8
06	HW	2	5/8
06	HW	3	7/8
06	HW	4	7/8
06	CW OR DX	3	7/8
06	CW OR DX	4	7/8
06	CW OR DX	6	7/8
08	HW	1	5/8
08	HW	2	5/8
08	HW	3	7/8
08	HW	4	7/8
08	CW OR DX	3	7/8
08	CW OR DX	4	7/8
08	CW OR DX	6	7/8
10	HW	1	5/8
10	HW	2	5/8
10	HW	3	7/8
10	HW	4	7/8
10	CW OR DX	3	7/8
10	CW OR DX	4	7/8
10	CW OR DX	6	7/8
12	HW	1	5/8
12	HW	2	5/8
12	HW	3	7/8
12	HW	4	7/8
12	CW OR DX	3	7/8
12	CW OR DX	4	7/8
12	CW OR DX	6	7/8
14	HW	1	7/8
14	HW	2	7/8
14	HW	3	1 1/8
14	HW	4	1 1/8
14	CW OR DX	3	1 1/8
14	CW OR DX	4	1 1/8
14	CW OR DX	6	1 1/8
16	HW	1	7/8
16	HW	2	7/8
16	HW	3	1 1/8
16	HW	4	1 1/8
16	CW OR DX	3	1 1/8
16	CW OR DX	4	1 1/8
16	CW OR DX	6	1 1/8
18	HW	1	7/8
18	HW	2	7/8
18	HW	3	1 1/8
18	HW	4	1 1/8
18	CW OR DX	3	1 1/8
18	CW OR DX	4	1 1/8
18	CW OR DX	6	1 1/8
20	HW	1	7/8
20	HW	2	7/8
20	HW	3	1 1/8
20	HW	4	1 1/8
20	CW OR DX	3	1 1/8
20	CW OR DX	4	1 1/8
20	CW OR DX	6	1 1/8

GUIDE SPECIFICATIONS

GENERAL

Furnish and install Titus Model HP Horizontal Concealed Direct Drive Fan Coil Units where indicated on the plans and in the specifications. Units shall be completely factory assembled, tested and shipped as one piece. All units shall be capable of meeting or exceeding the scheduled capacities for cooling, heating and air delivery. All unit dimensions for each model and size shall be considered maximums. Units shall be ETL listed in compliance with UL/ANSI Standard 1995, and be certified as complying with the latest edition of AHRI Standard 440.

CONSTRUCTION

All unit chassis shall be fabricated of heavy gauge galvanized steel panels. All exterior panels shall be insulated with 1/2" thick fiberglass insulation with a maximum k value of .24 (BTU • in) / (hr • ft² • °F) and rated for a maximum air velocity of 5000 f.p.m. Insulation must meet all requirements of ASTM C1071 (including C665), UL 181 for erosion, and carry a 25/50 rating for flame spread/smoke developed per ASTM E-84, UL 723 and NFPA 90A.

Option: Provide foil-faced insulation in lieu of standard. Foil insulation shall meet or exceed the requirements stated above, and in addition meet ASTM Standards C-665 and C-1136 for biological growth in insulation. Insulation shall be lined with aluminum foil, fiberglass scrim reinforcement, and 30 pound kraft paper laminated together with a flame resistant adhesive. All exposed edges shall be sealed to prevent any fibers from reaching the air stream.

Option: Provide Elastomeric Closed Cell Foam Insulation in lieu of standard. Insulation shall conform to UL 181 for erosion and NFPA 90A for fire, smoke and melting, and comply with a 25/50 Flame Spread and Smoke Developed Index per ASTM E-84 or UL 723. Additionally, insulation shall comply with Antimicrobial Performance Rating of 0, no observed growth, per ASTM G-21. Polyethylene insulation is not acceptable.

All concealed units shall have a minimum 1 1/4" duct collar on the discharge. Plenum units shall have a minimum 1" duct collar on the return.

Option: For concealed units, provide a hinged bottom access panel either solid or with bottom return single deflection grille. A telescoping plenum section is available with bottom return option.

All exposed units shall have exterior panels fabricated of galvanized steel.

Option: For exposed units, the side and bottom access panels shall be attached with quick open fasteners to allow for easy removal and access for service.

Option: For exposed units, provide double deflection discharge grille and either a rear return or bottom return single deflection grille, powder coat painted to match unit color. Supply and return duct connections are available.

Unit mounting shall be by hanger holes provided at a minimum of four locations.

SOUND

Units shall have published sound power level data tested in accordance with AHRI Standard 260-01.

FAN ASSEMBLY

Unit fan shall be a dynamically balanced, forwardly curved, DWDI centrifugal type constructed of 18 gauge zinc coated galvanized steel for corrosion resistance. Motors shall be high efficiency, permanently lubricated sleeve bearing, permanent split-capacitor type with UL and CSA listed automatic reset thermal overload protection and three separate horsepower taps. Single speed motors are not acceptable.

The fan assembly shall be easily removable for servicing the motor and blower at, or away from the unit. The entire fan assembly shall be able to come out of the unit by removing four nuts per fan and unplugging the motor(s). Plenum unit fan assemblies shall be easily serviced through the filter opening or through the bottom panel.

Option: Provide an electronic (SCR) fan speed controller as an aid in balancing the fan capacity. The speed controller shall have a turn down stop to prevent the possibility of harming the motor bearings, and incorporate electrical noise suppression to minimize noise on the incoming power lines. The SCR fan speed controller is only available for high speed setting.

Option: Provide Electronically Commutated (EC) Motor capable of operation with 3 speed thermostat.

Option: Provide Electronically Commutated (EC) Motor capable of operation with 3 speed thermostat. Each speed shall be manually adjustable in the field. All manual speed adjustments shall be stored in non-volatile memory.

Option: Provide Electronically Commutated (EC) Motor capable of variable speed operation. Motor shall be capable of accepting a 2-10 VDC output from BAS.

COILS

All coils shall be AHRI 410 certified and tagged with an AHRI 410 label.

All cooling and heating coils shall optimize rows and fins per inch to meet the specified capacity. Coils shall have seamless copper tubes and shall be mechanically expanded to provide an efficient, permanent bond between the tube and fin. Coil tubes shall be 3/8" outside diameter with .012" tube wall thickness. Fins shall have high efficiency aluminum surface optimized for heat transfer, air pressure drop and carryover.

All coils shall be hydrostatically tested at 450 PSIG air pressure under water, and rated for a maximum of 450 PSIG working pressure at 200°F.

Direct expansion cooling coils shall include a fixed orifice distributor. All evaporator coils shall be factory sealed and charged with a minimum 5 PSIG nitrogen or refrigerated dry air.

Steam coils shall be standard steam type suitable for temperatures above 35°F and 15 PSIG maximum working pressure.

All coils shall be provided with a manual air vent fitting to allow for coil venting.

Option: Provide coil tubes with 1/2" outside diameter and .016" tube wall thickness.

Option: Provide coil tubes with 1/2" outside diameter and .025" tube wall thickness.

Option: Provide automatic air vents in lieu of manual air vents.

Cooling and heating coils shall be in a common tube sheet. Heating coils shall be furnished in the reheat or preheat position.

GUIDE SPECIFICATIONS

DRAIN PANS

Primary condensate drain pans shall be single wall; heavy gauge galvanized steel for corrosion resistance, and extend under the entire cooling coil. Drain pans shall be of one-piece construction and be sloped for condensate removal.

The drain pan shall be externally insulated with a fire retardant, closed cell foam insulation. The insulation shall carry no more than a 25/50 Flame Spread and Smoke Developed Rating per ASTM E-84 and UL 723 and an Antimicrobial Performance Rating of 0, no observed growth, per ASTM G-21.

Option: Provide a single wall primary drain pan constructed entirely of heavy gauge stainless steel for superior corrosion resistance. Stainless steel drain pans shall be externally insulated and meet or exceed the requirements stated above.

Option: Provide a secondary drain connection on the primary drain pan for condensate overflow.

Option: Provide a condensate overflow switch in the primary drain pan for condensate overflow.

FILTERS

All plenum and exposed units shall be furnished with a minimum 1" nominal glass fiber throwaway filter. Filters shall be tight fitting to prevent air bypass. Plenum and exposed unit filters shall be easily removable from the bottom of the unit without the need for tools.

Option: Provide unit with 1" or 2" pleated filters rated at 25-30% efficiency and MERV 6 based on ASHRAE 52.2 - 1999.

MIXING BOX SECTION

Provide a fully insulated integral mixing box section with return and outside air dampers, including the interconnecting damper linkage. Mixing box section shall be shipped attached to the concealed plenum unit as an assembly.

Option: Factory-provided damper actuator to be mounted.

ELECTRICAL

Units shall be furnished with single point power connection. Provide an electrical junction box with terminal strip for motor and other electrical terminations. The factory mounted terminal wiring strip consists of a multiple position screw terminal block to facilitate wiring terminations for the electric control valves and thermostats.

ELECTRIC HEAT

Furnish an electric resistance heating assembly as an integral part of the fan coil unit, with the heating capacity, voltage and kilowatts scheduled. The heater assembly shall be designed and rated for installation on the fan coil unit without the use of duct extensions or transitions, and be located in the unit as to not expose the fan assembly to excessive leaving air temperatures that could affect motor performance.

The heater and unit assembly shall be listed for zero clearance and meet all NEC requirements, and be ETL listed with the unit as an assembly in compliance with UL/ANSI Standard 1995.

All heating elements shall be open coil type Ni-Chrome wire mounted in ceramic insulators and located in an insulated heavy gauge galvanized steel housing. All elements shall terminate in a machine staked stainless steel terminal secured with stainless steel hardware for corrosion resistance. The element support brackets shall be spaced no greater than 3-1/2" on center. All internal wiring shall be rated for 105°C minimum.

All heaters shall include over temperature protection consisting of an automatic reset primary thermal limit and back up secondary thermal limit. All heaters shall be single stage unless noted otherwise on the plans.

All units with electric heat shall be provided with an incoming line power distribution block, designated to accept single point power wiring capable of carrying 125% of the calculated load current.

PIPING PACKAGES

Provide a standard factory assembled valve piping package to consist of a 2 or 3 way, on/off, motorized electric control valve and two ball isolation valves. Control valves are piped normally closed to the coil. Maximum entering water temperature on the control valve is 200°F, and maximum close-off pressure is 40 PSIG (1/2"), 20 PSIG (3/4"), or 17 PSIG (1"). Maximum operating pressure shall be 450 PSIG.

Option: Provide 3-wire floating point modulating control valve (fail-in-place) in lieu of standard 2-position control valve with factory assembled valve piping package.

Option: Provide high pressure close-off actuators for 2-way on/off control valves. Maximum close-off pressure is 50 PSIG (1/2"), 25 PSIG (3/4"), or 20 PSIG (1").

Option: Provide either a fixed or adjustable flow control device for each piping package.

Option: Provide unions and/or pressure-temperature ports for each piping package.

Piping package shall be completely factory assembled, including interconnecting pipe, and shipped separate from the unit for field installation on the coil, so as to minimize the risk of freight damage.

NOTES

